

## 4.5V-42V Vin, 5A, High Efficiency Step-down DCDC Converter with Programmable Frequency

GFBUVS FT

E FTDS U POA

- 
- 
- 
- 
- 
- 
- 
- 
- 
- 
- 
- 
- 
- 

B MDBU POTA

- 
- 
- 
- 

A

U DBMB MDBU POA

A

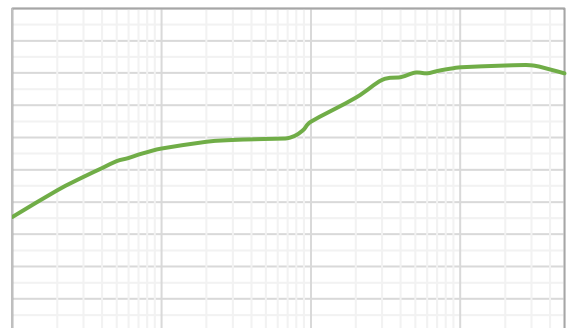
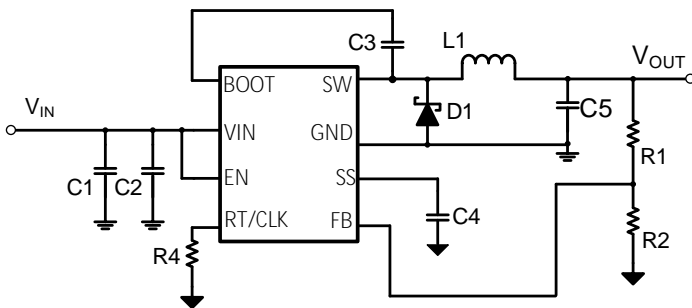

4.5V-42V, Asynchronous Buck Converter

**SF TPOA TUPS A**

**EF DFÆSEFSAOGPSNBU POA**

**BCTPMWUFANBY NVN SBU OHTA**

- (1)
- (2)

**OADPOG HVSBU POA**

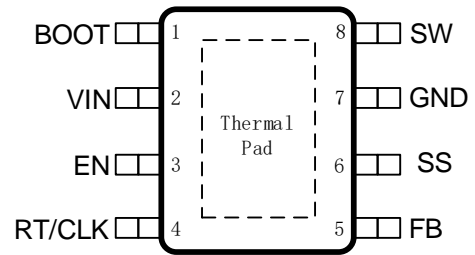

**OAGVODU POTA**

---

**S F D P N N F O E F E A P F S B U O H A P O E U P O T A**

**F T E A S B U O H T A**

- (1)
- (2)

**U I F S N B M A O G P S N B U P O A**



**F M F D U S D B M D I B S B D U F S T U D T A**



A

A

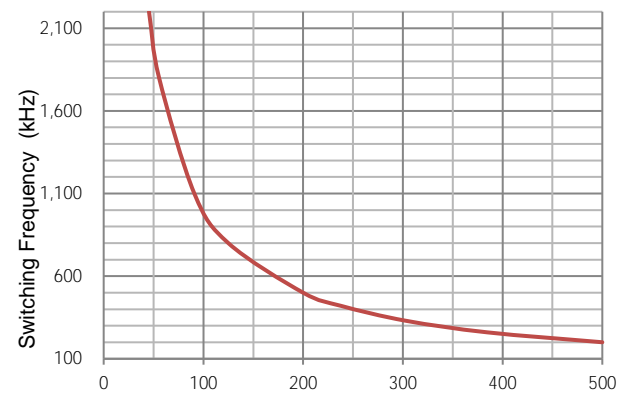
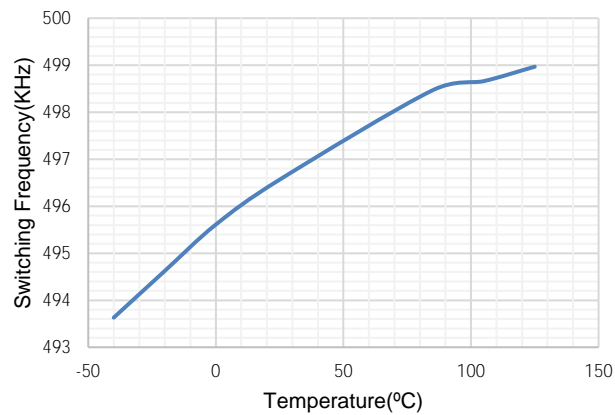
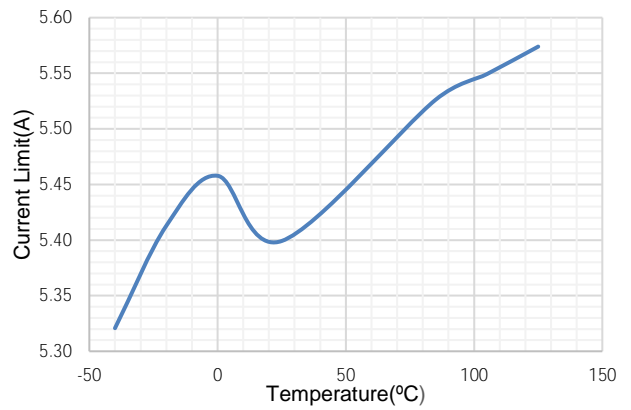
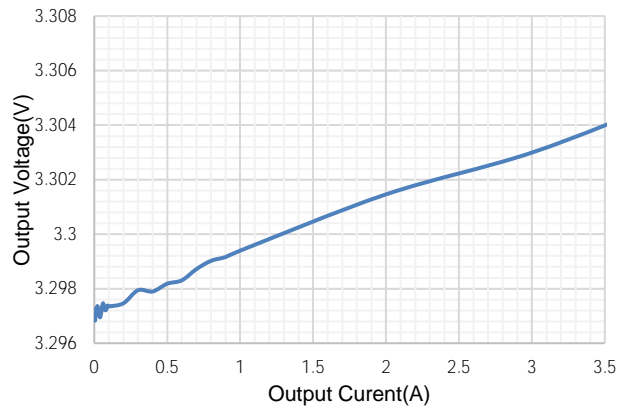
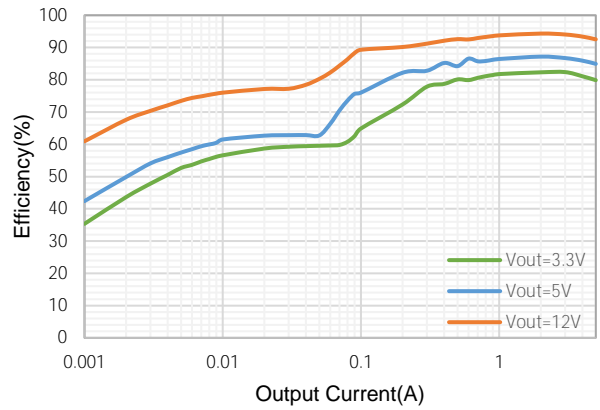
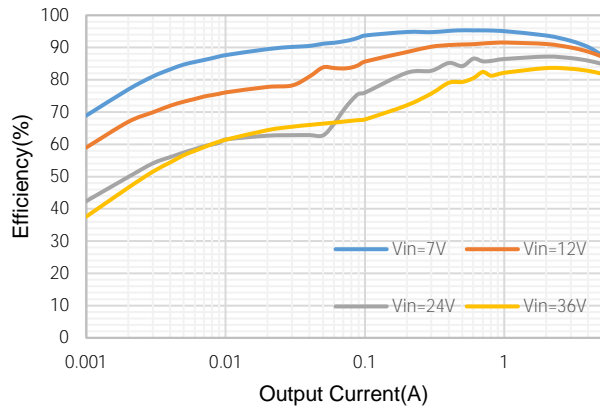
# U DBMDI BSBDUFS TU DTA



# A

# GVODU POBMCMPDLÆ BHSBN A

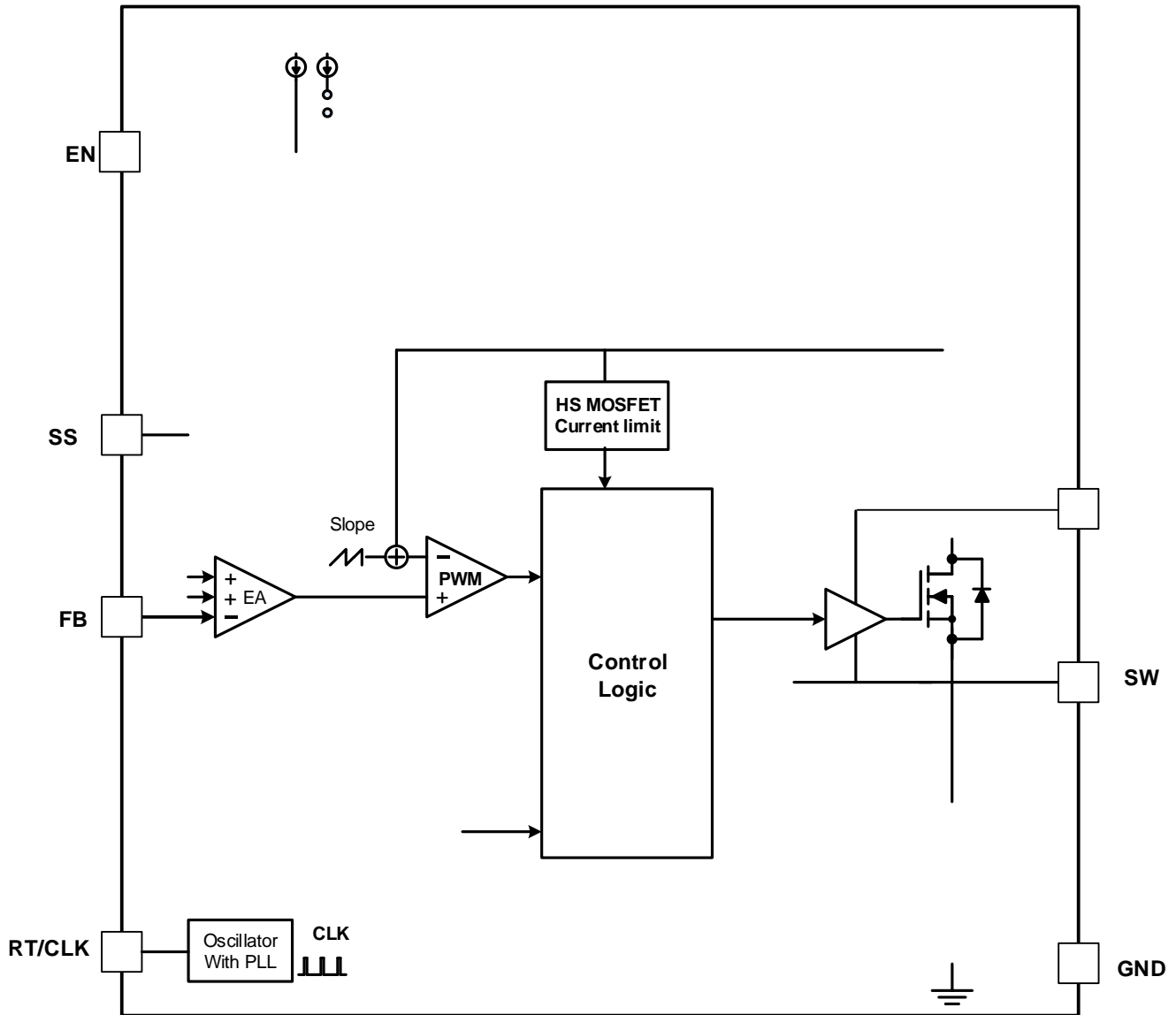

---

**P FSBU POA**

$$1 \quad \frac{0.875}{3.125}$$

$$2 \quad \frac{1 \cdot 1.05}{1.05 \cdot 1 \cdot 4}$$

•  
•

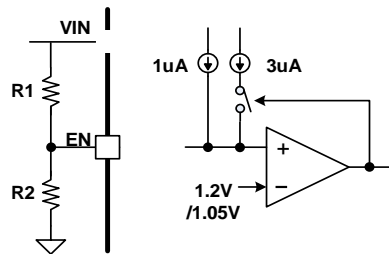

±

— 1 —

•  
•

$$\frac{3}{0.8}$$

•  
•



---

100000

5

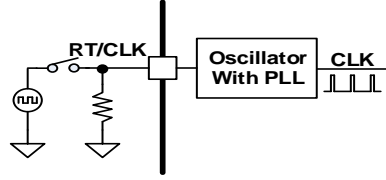



## B MDBU POAOGPSNBU POA

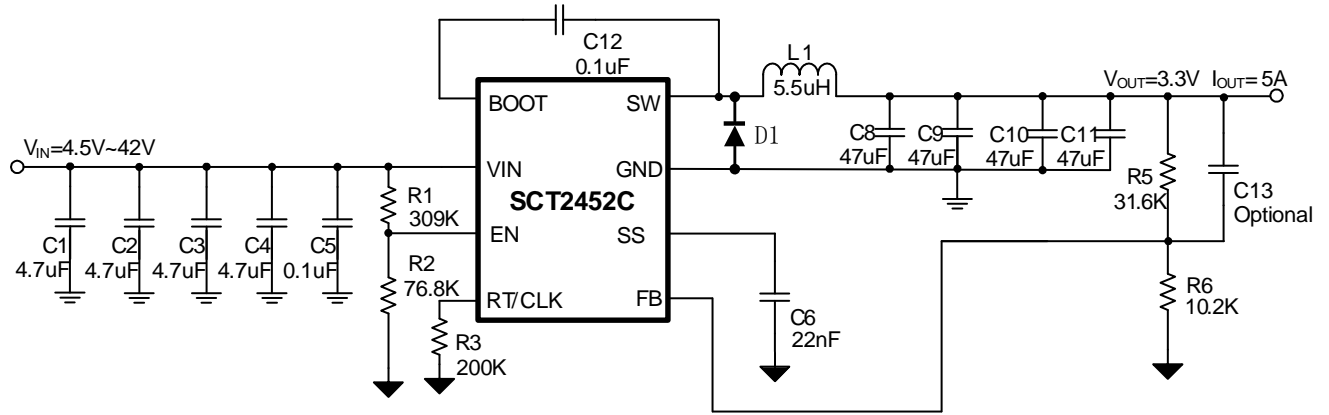

---



\_\_\_\_\_

- 
- 
- 
- 
- 

\_\_\_\_\_ 1 \_\_\_\_\_

- 
- 
- 
- 
- 
- 

$$\frac{\overline{2}}{2 \frac{1}{12} 2}$$

- 
- 
- 
- 





$$\frac{-}{-} \quad \frac{2}{2}$$





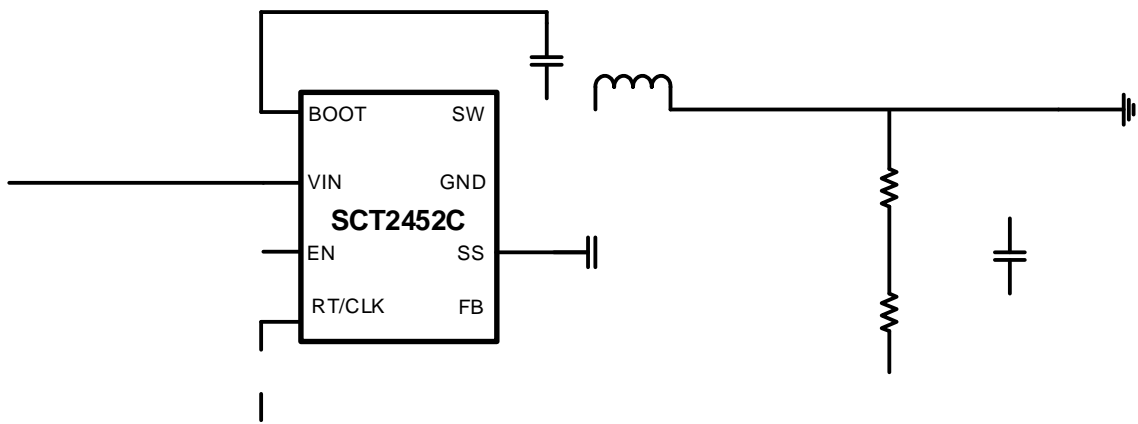



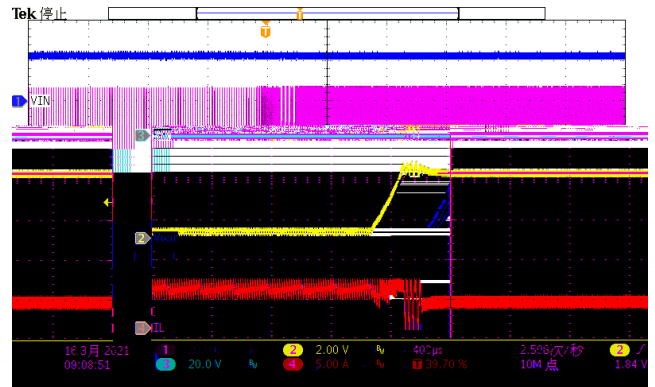
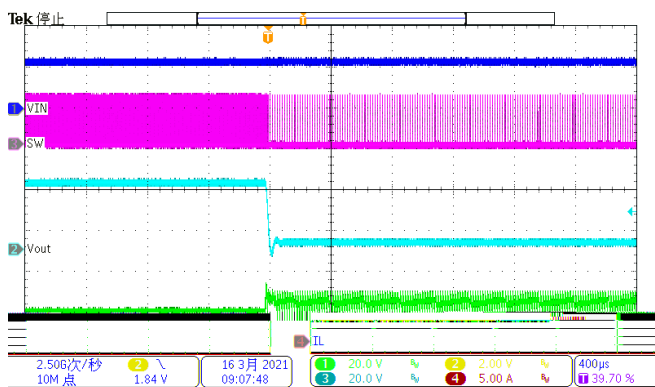
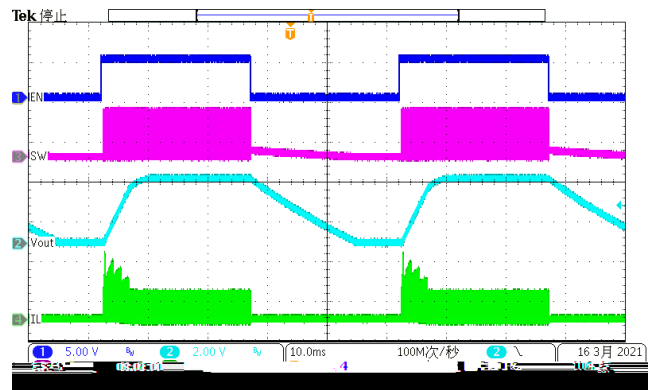
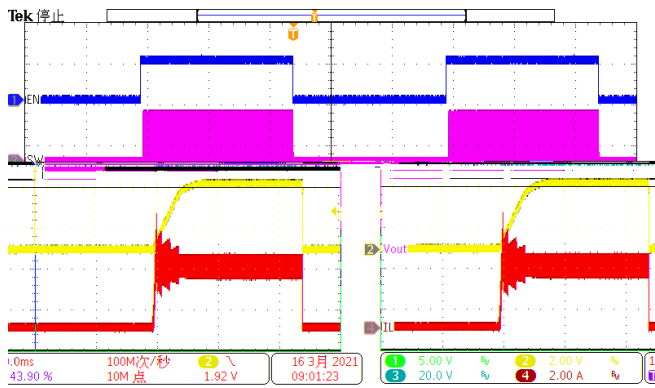
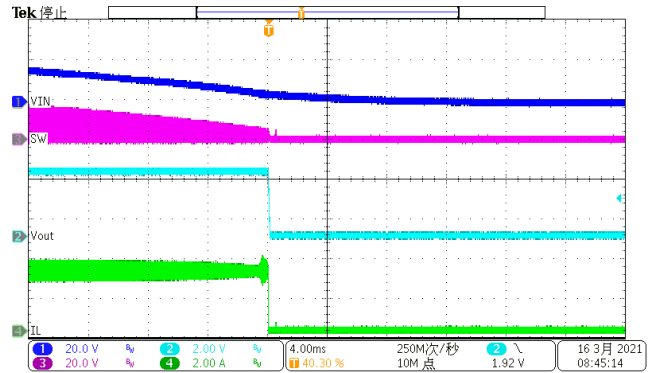
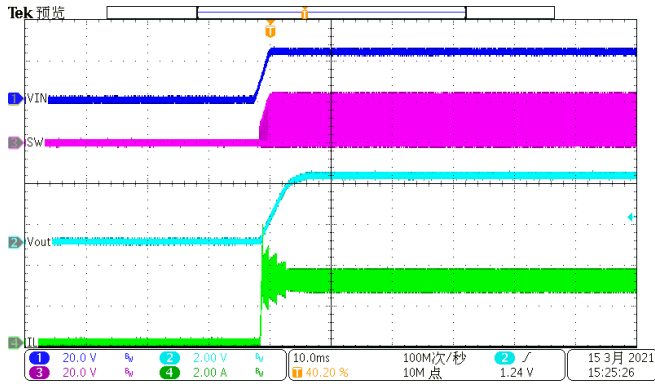

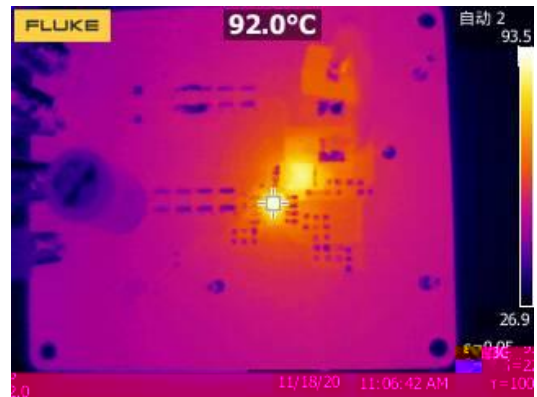
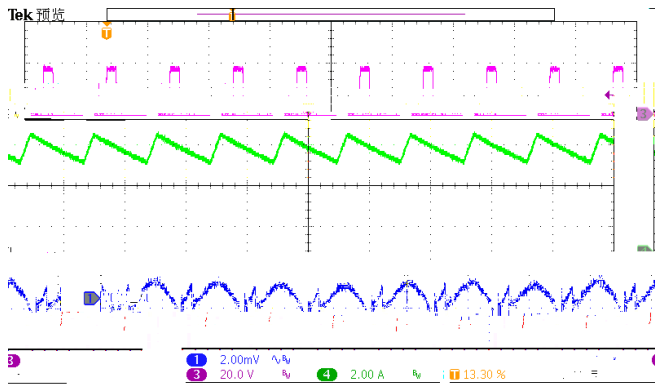
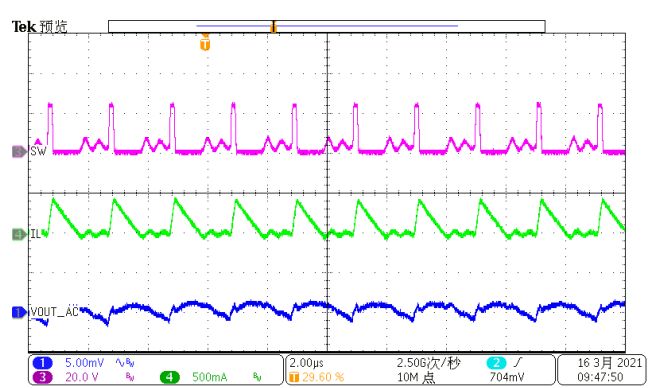
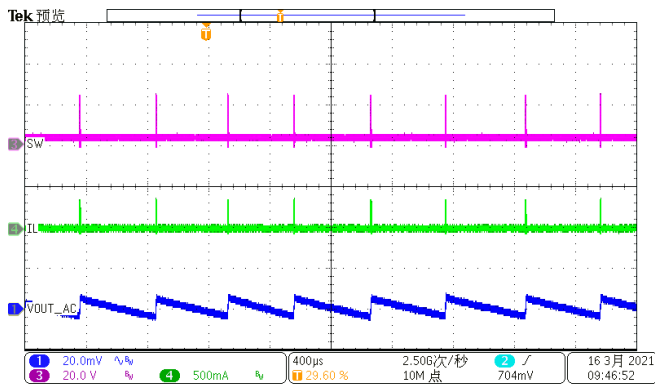
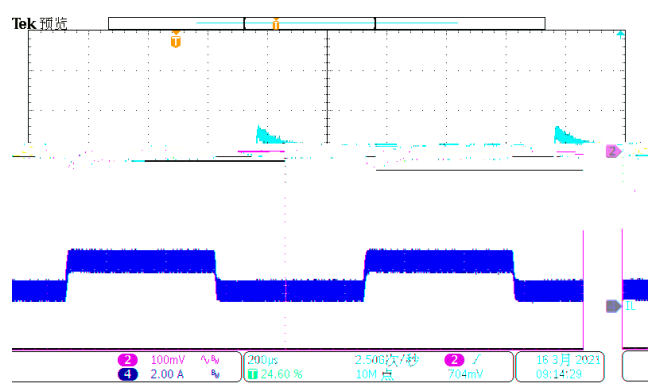
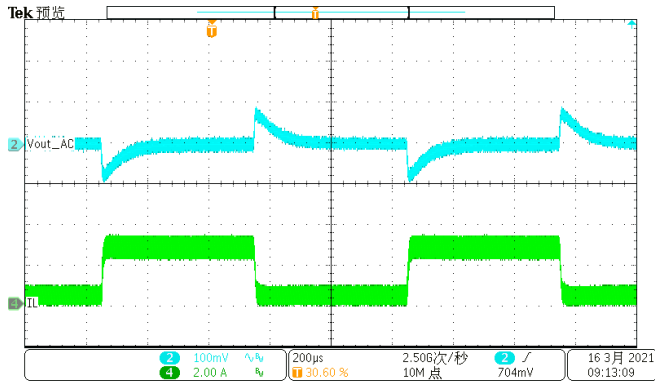

- 1.
- 2.
- 3.
- 4.
- 5.
- 6.
- 7.
- 8.
- 9.
- 10.

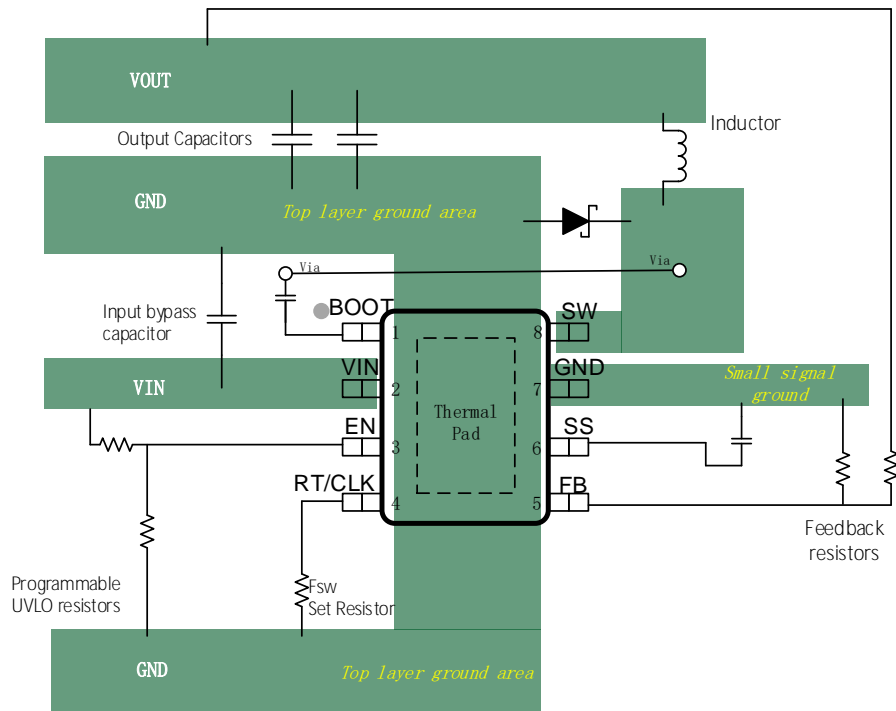

# BDLBHFAOGPSNBU PO

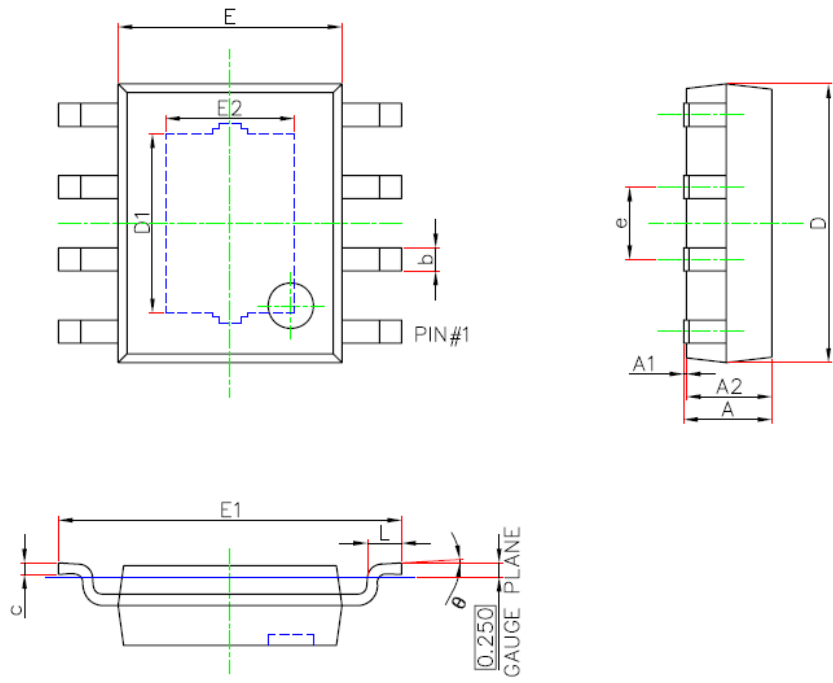

$\theta$				

- 1.
  - 2.
  - 3.
  - 4.
  - 5.
  - 6.
- A**

**A**

**UB FBOE AFFMOGPNBU POA**  
**A**

