

3.5V-36V Vin, 6A, High Efficiency Synchronous Step-down DCDC Converter

External bias option for improved efficiency
 Parallel input path to minimize switch node ringing

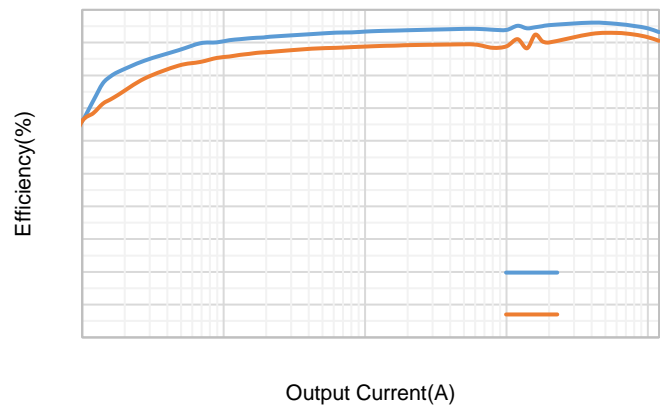

POWER GO4 r n(% of (F)14(B)-4()9

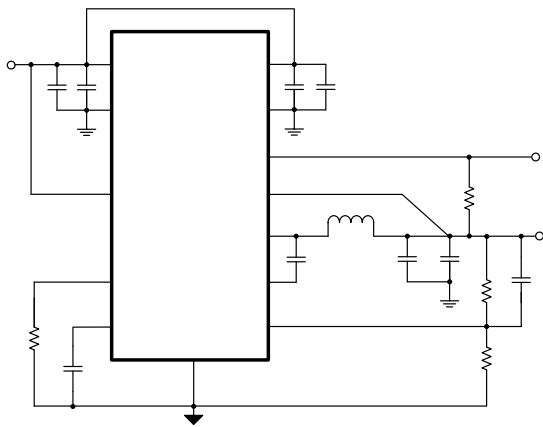
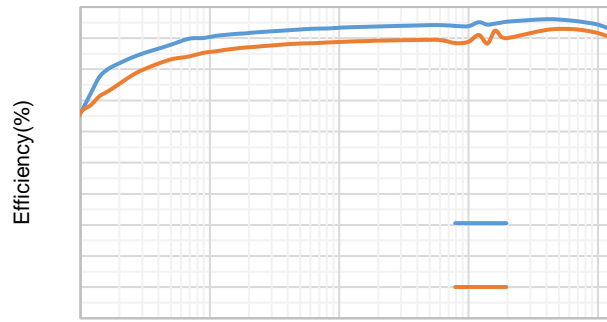

Output Current(A)

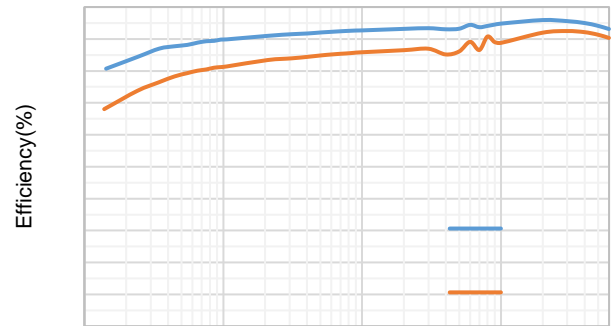

Output Current(A)

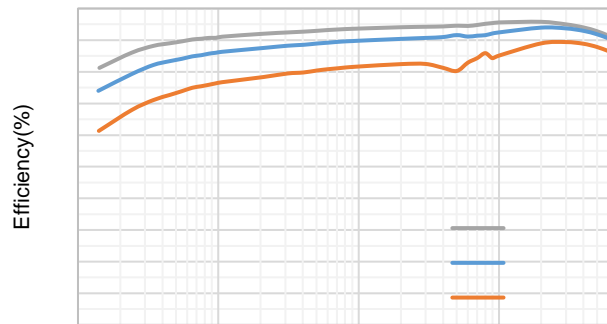

Output Current(A)

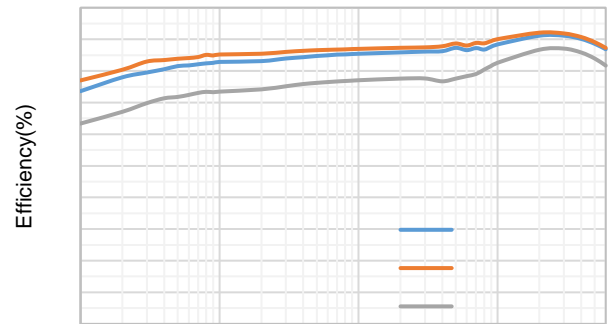

Output Current(A)

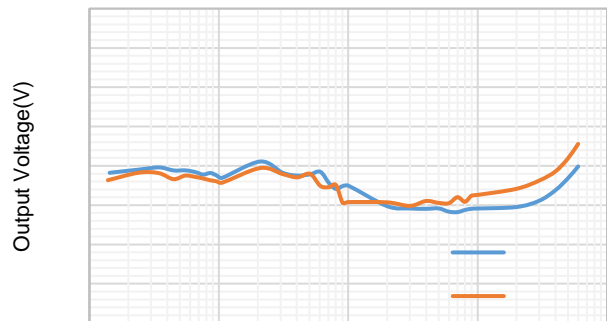

Output Current(A)

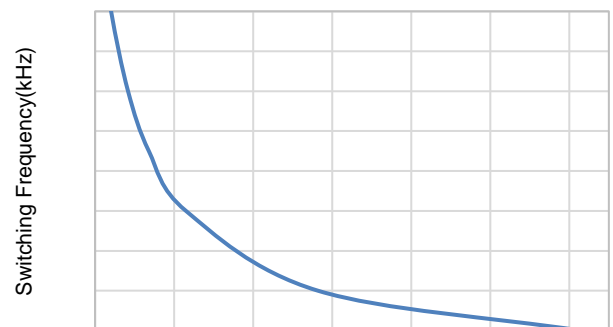

Switching Frequency(kHz)

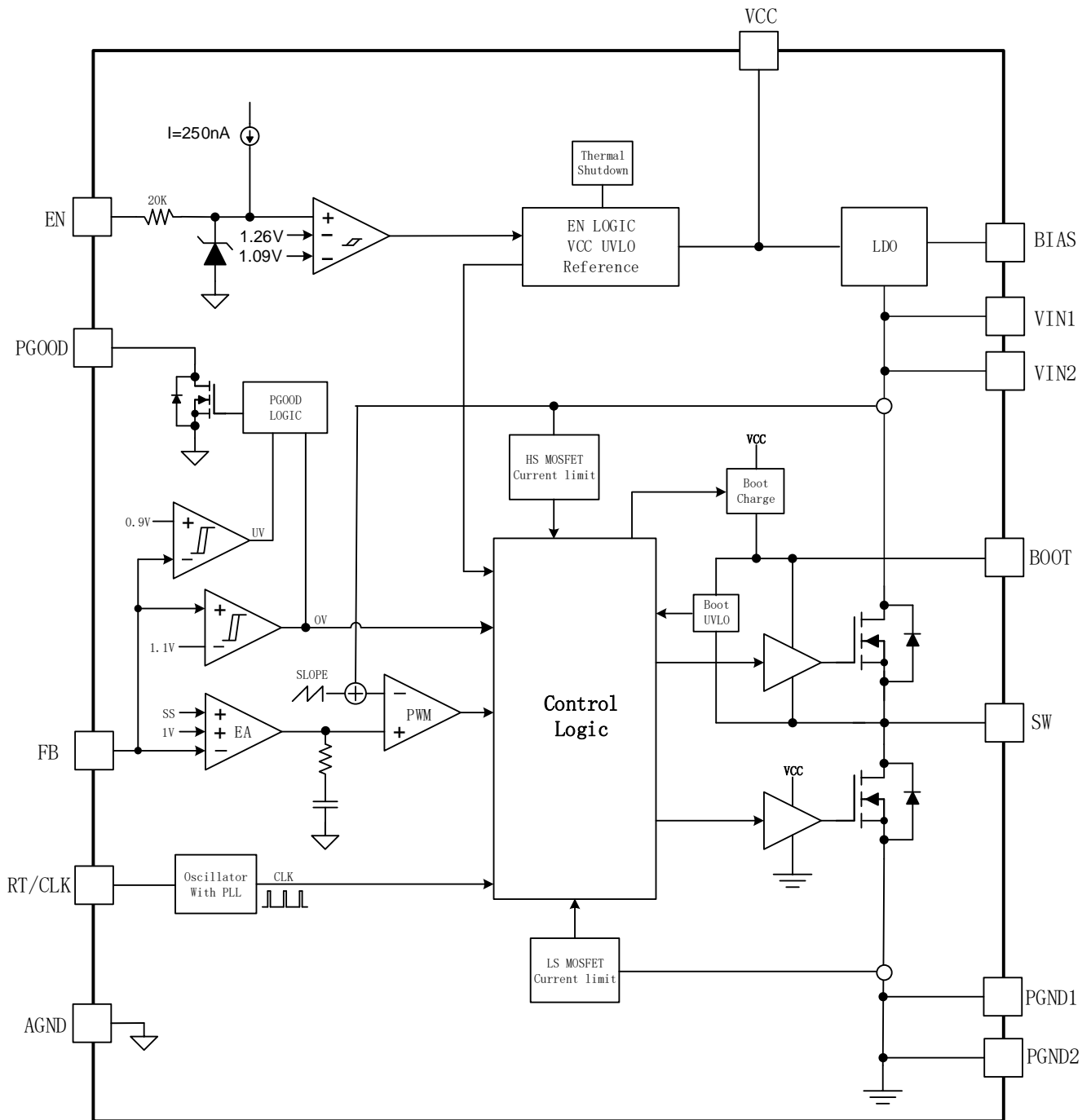

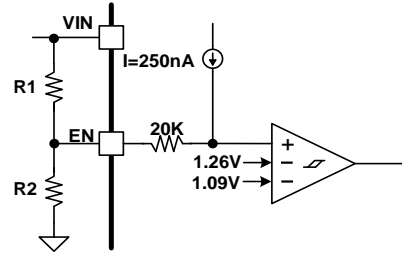

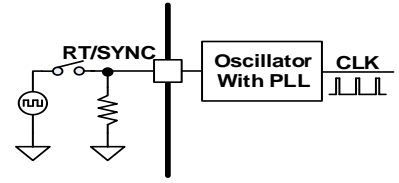

—

—

—

—





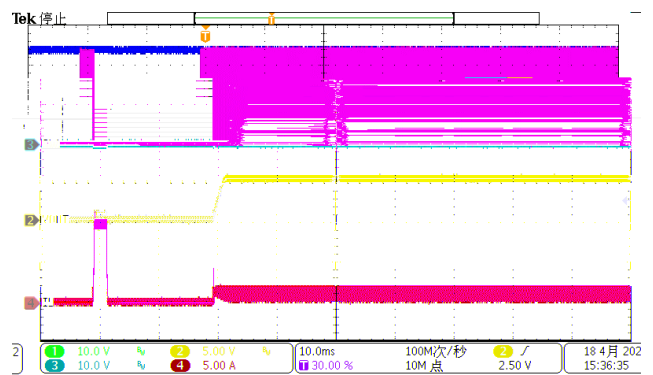
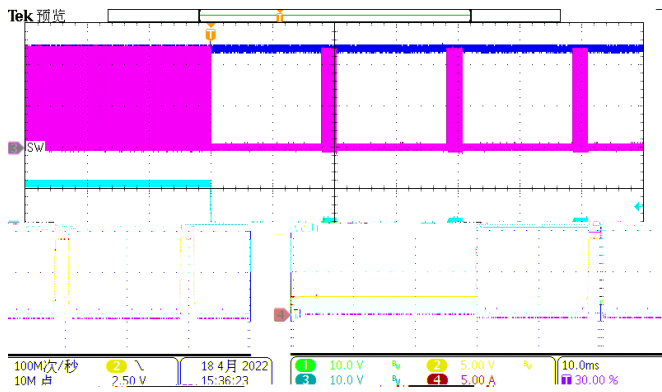
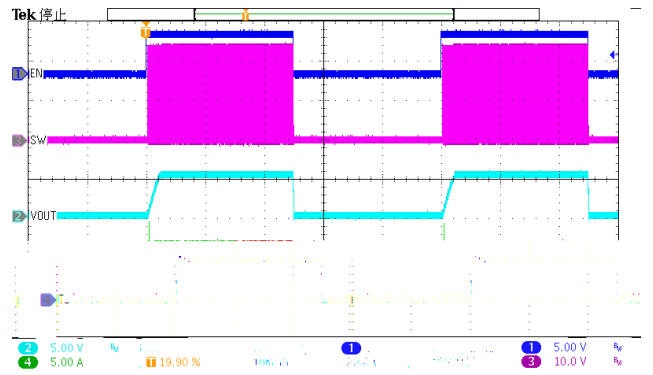
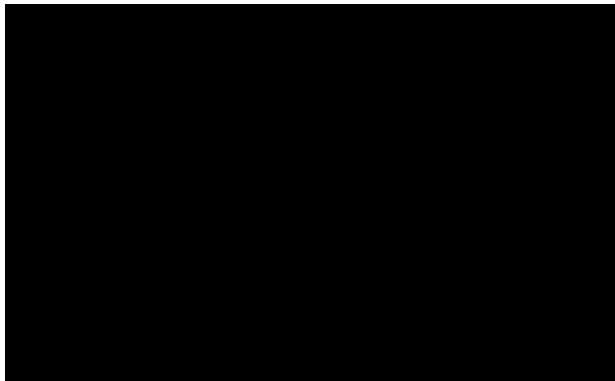
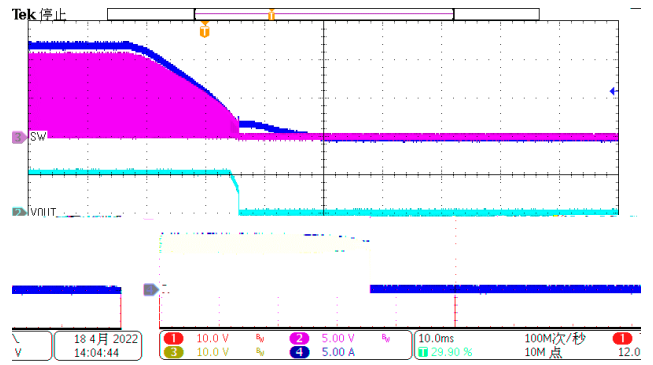
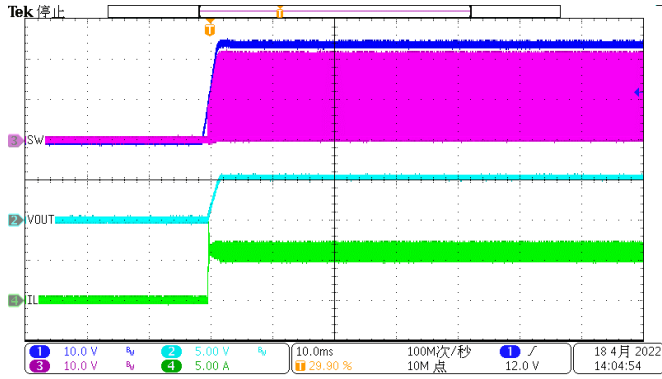

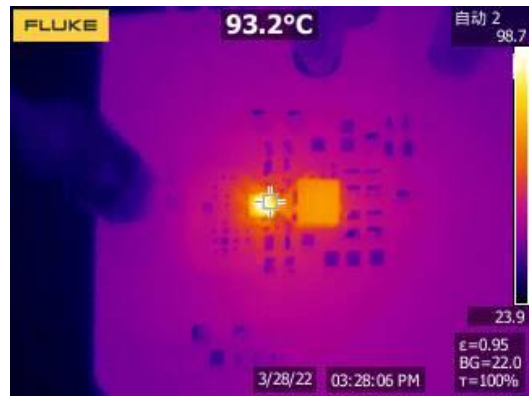
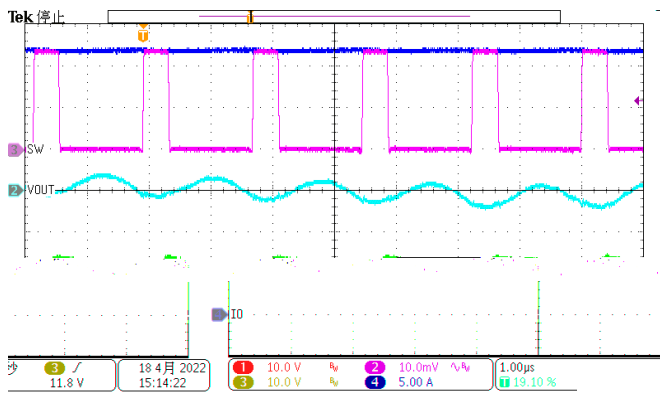
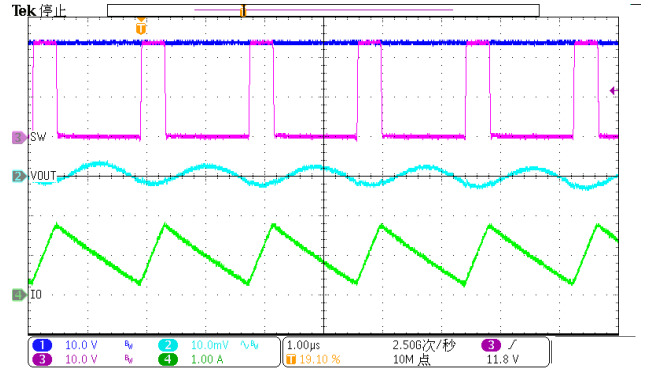
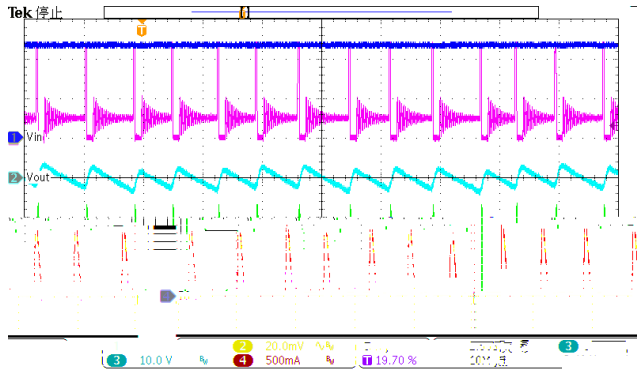
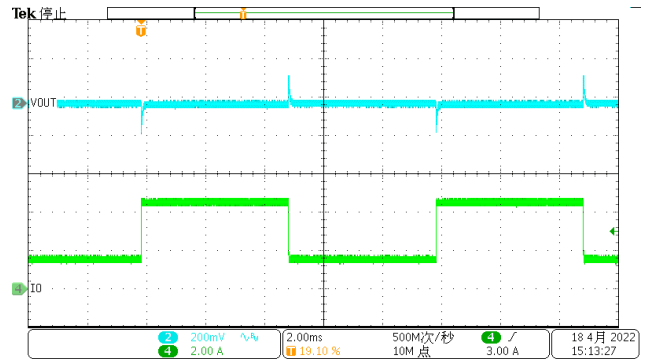
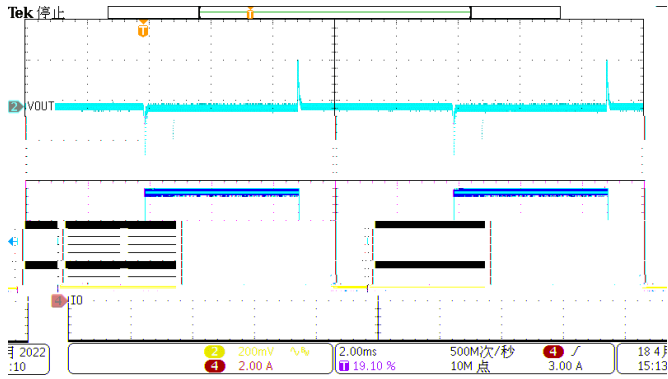

1.

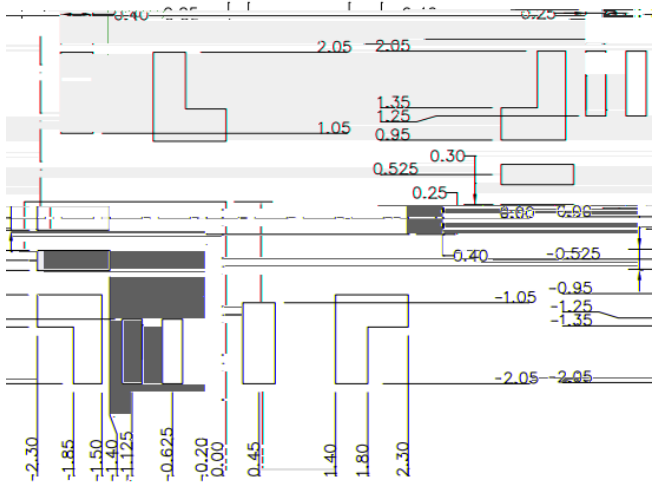
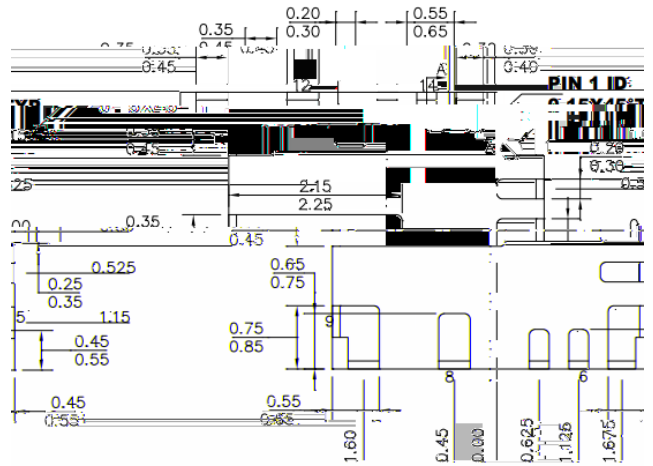
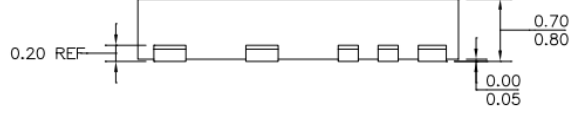
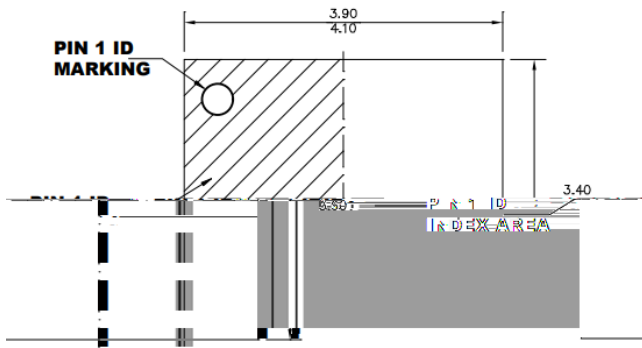

- 1.
- 2.
- 3.
- 4.
- 5.

