

G7 H&&) \$

REVISION HISTORY

GHM 3I Z g f _h b bthg f Z b _hf Z g f tya g thg
 K bthg)3I h thg
 K bthg +3N Z aZ Zg bZeZ dZthg Z hf
 K bthg , 3N Z : G= hgg thgh_Z dZthg tya Z Zg Z +
 K bthg -3N Z = OB HK= K B HKF: MBIG

DEVICE ORDER INFORMATION

CF89F56 @ 89J=9	D57?5; =B; HMD9	G5 B85 F8 D57? EHM	D57?5; 9 A5F? =B;	D=BG	D57?5; 9 89G7F=DHCB
L<M++.) I: K	MZ K e	.)))	++.)	+	J G- +E

ABSOLUTE MAXIMUM RATINGS

89G7F=DHCB	A=B	A5L	I B=H
OB% G	-),	2	O
; LM	LP -),	LP /	O
LP	-	OB),	O
FH=	-),	/	O
;	-),	/	O
L E	-),	/	O
OHNM	-),	/	O
I	-),	/	O

H Z tya c g b f

PIN CONFIGURATION

Hcd JYk

: [i fY%"&-@UX'D'Ugh]WE: B
 +f f , f f

OHNM	<p>OHNMb h g a h heZ h_a d ěh <hgg OHNM h a h Z Z bh h_a ěh b e D a OHNM g ě Z Z Z Z _hf a LP gh OB ah e Zeh Z hb hg a OHNM g ě Z : Z ě aZg+. f ěb b I F%NLF h <<F f h e ěg <hgg a ě ěag, Z < ;</p>
FH=	/

G7 H&&) \$

ELECTRICAL CHARACTERISTICS

0.6 +0.6--) < +. <% bZe Ze b g +. <

GMA 6 C @	D5 F5 A9 H9 F	H9 GH'7 CB8 #CB	A-B	HMD	A5 L	I B=H
------------------	----------------------	------------------------	------------	------------	-------------	--------------

Dck Yf'Gi dd'miUbX'Ci hdi h

O _{EG}	H Z _{tg} _{tg} heZ		- .		1	O
O _{EGNOEH}	O _{tg} NOEH b _{tg} a ahe		-	- +.	- .	O
O _{EGNOEH ARL}	O _{EG} NOEH A b			+0)		f O
B=	La h g g	G6) %F Z hg O _{EG} _{tg}			,	:
B	J b g g _hf O _{EG}	G6+0%Ch 6. 0%Ch Ch %Ch b at _g F Z hg O _{EG} _{tg}		-)		:
O<<	O<< _{tg} gZeE=H _{tg} h heZ	B<<6) f :	- 0.	.	. +.	O
O<<XEK	O<< _{tg} gZeE=H ChZ _{tg} h g	B<<6. f :) .		
B<<XEF	O<< _{tg} gZeE=H g _{tg} b	O<< ah h h g		+0		f :

FYZfYbW'UbX'7cbf'c'@cd

O _K	K _ g heZ h _ ;	- . 050 _{tg} 10 Z M f 6+. H<) . 2-) /) / /	O
B;	; _{tg} e ZdZ g	O ; 6 +0)		g

Dck Yf'ACG: 9Hg

K=LHGXA	Ab a b Mhg- b Zg	O<<6. O		- +		f
K=LHGXE	Eh b Mhg- b Zg	O<<6. O		0		f

9bUV'YUbX'GcZ'ghUfh

O _{GXA}	gZ e aba a ahe			1	+	O
O _{GXE}	gZ e Ch a ahe) ,			O
B _G	gZ e _{tg} _{tg} g	G6 O		.	+	:
B _{GXARL}	gZ e _{tg} a b g			-		:
M _{LL}	Lh _ Z _{tg} f	OHNM) h 2)				f

CdYfUqcb'AcXY

O _{F=XI P F}	I P F f h ba Ch b aba a ahe	O<<6. O		- .		O
O _{F=XNLF}	I F f h ba NLF Ch b a ahe			.	.	O
O _{F=XI F}	I F f h _{tg} Ch b Ch a ahe) 2	O

Gk]HW]b[' : fYei YbWn

LP	L b at _g _ g	L E6) O		-))		dA
		L E6h g		1))		dA
		L E6. O		+))		dA
M _{HGXMF}	F _{tg} f f Hg- _{tg} f	Z Zg b g		0)		g
M _{H XMF}	F _{tg} f f H _ _{tg} f			+.)		g

Dck Yf' ; ccX

I _{Kb_{tg} _{tg}}	O ; b _{tg} % g Z h _O _K hh			2.		
I _{Z_{tg} _{tg}}	O ; Z _{tg} % g Z h _O _K			1.		
I _{Kb_{tg} h}	O ; b _{tg} % g Z h _O _K			.		
I _{Z_{tg} h}	O ; Z _{tg} % g Z h _O _K hh) .		
I _{M=}	I Ch h aba _{tg}) .		f
O _I	I h hh I Ch h g g a	B 6- f :) /		O
B _{XE : D}	I h hh I e ZdZ g	O _I 6. O		.		:

DfchWqcb

- h f h _{tg} h f Z_{tg} Ch h g g hf +) 2 L Ch h g < h g g M agh Ch < h % : Ch K a K
I h he Etgd 3 L < M ++.)



GMA6C@	D5F5A9H9F	H9GH'7CB8-HCB	A-B	HMD	A5L	I B-H
B _{xi}	EL FHL M h bb g ef b	hf h h Zlg	.	/ 0	1	:
B _{xg}	EL FHL Mg Z b g ef b	hf Zlg h h %F H= hgg h O<<		+		:
M _{AB<NI}	Ab Zblg lf			0		f
O _{HOI XK}	O ; HOI a ahe h_Ok	O ; b lg		++		
O _{HOI X}	O ; HOI a ahe h_Ok	O ; Z lg		0		
O _{NOI X}	O ; NOI a ahe h_Ok	O ; Z lg		0.		
M ₌	Ma f Ze a h g a ahe	Mc b lg		.)	<
	A b			+)	<

G7 H&&) \$

FUNCTIONAL BLOCK DIAGRAM

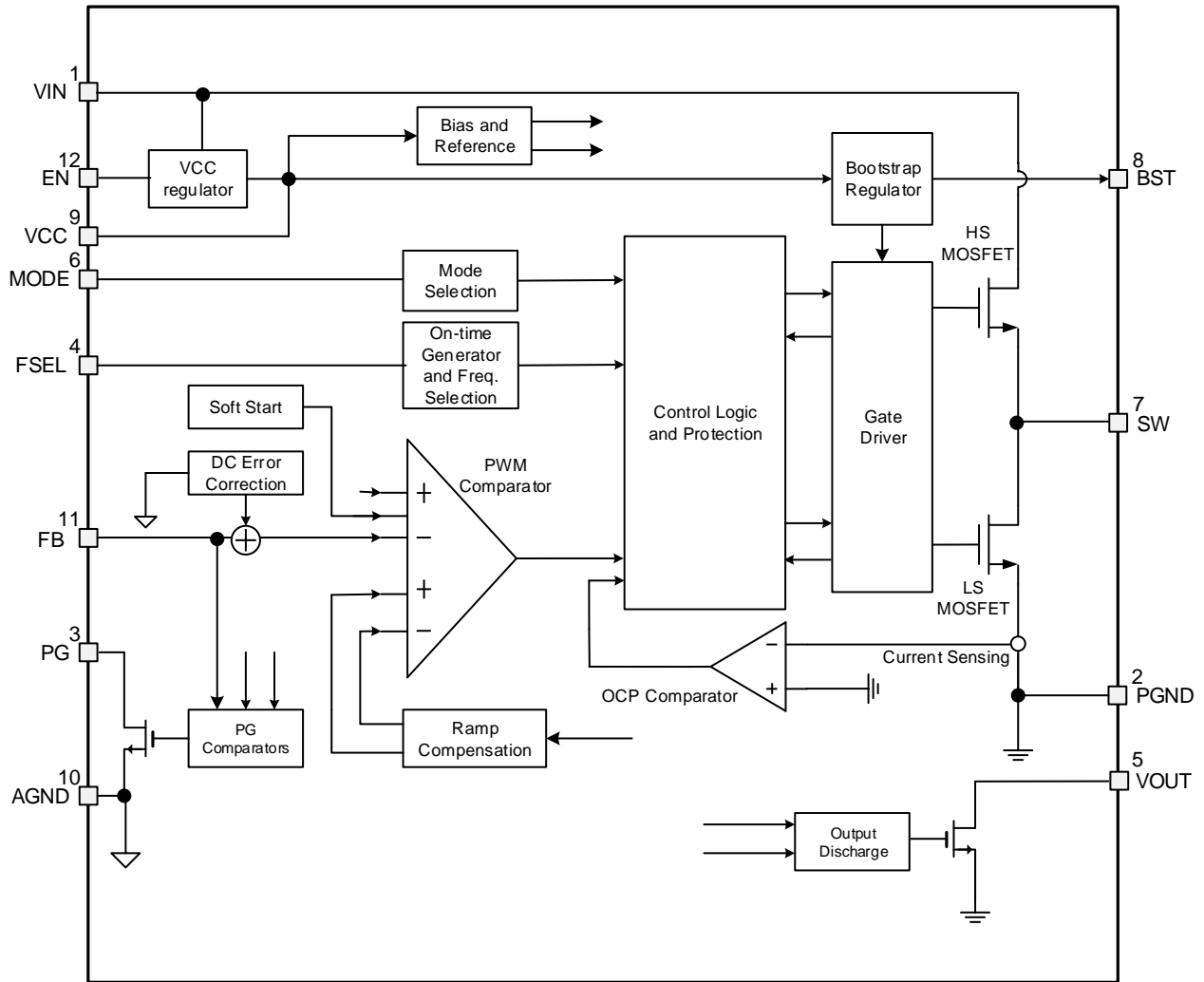

b 1 g hgZe; d =Z Zf

OPERATION

Cj Yfj JYk

Ma L<M++.) b Z-.O- 1O t% : hg t h h g a h g d hg ba t-t -+f K hg
aba- b Zg Gf 7KHODP-U h FHL M Bf ef g a <hg Zg hg- t <HM f h hg heh
ē h heZ % h b t g g t Zg t Zg b g hg Zg t t a gZe
_ g hf g Z t g b g

Ma b at _ Wg b e Z e %)) dA %)) dA Zg +FA % t b g L E Z % h h t b
ba a h _ bbg h a gZe hf hg g b Ma L<M++.) _ Z Zg t gZe f h_- hZ
t h Z hb ē t a g Zg h heZ h ahh t Z Ma b _ Z a _ g
h Z t g f h Z t a t t 3l e g Fh ē t N

h%a 4 - b FHL M g h h Zg tgd g_hf h h f Ztg Ztg a hg Zg h
 A g h _bbg tga 4Z b f a4 aZga Z 4Z

9bUV`Y`UbXI bXYf`Jc`HJ`Y`@`W`ci`hH`fYg`c`X`

Ma L<M++.) b gZ e a g a OEG tgd heZ b Zh - .OZg a G tgd heZ a gZ e
 a ahe h_ 10 Ma b b bZ e a g a OEG tgd heZ Z4 4 -Oh a g a G tgd heZ b
 4 O: g tgd gZe . : e g h h G tgd Z4 a b gZ e a g G tgd 4Z

G tgd b Zaba heZ tgd aZ Zg hgg hOEG b e h Z a b

h Zaba f NOEH a ahe%hgg Zg gZe b h bb K Zg K+ ah g tgd b 2_hf OEG
 h G Ma NOEH b tgd Zg Z4 a ahe Zg Ze 4 Z tgd Zg Z tgd + b e

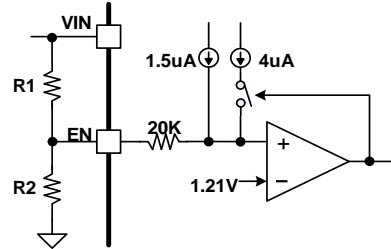

a

O_b b b tgd a ahe h_O tgd NOEH

O_{Z4b} Z4 tgd a ahe h_O tgd NOEH

b 2 L f NOEH gZ e bb

Ci`hdi`hJc`HJ`Y`

Ma L<M++.) 4 a tgd gZe _ g heZ Z) /O ba he Zg h a h Z tgd f Z
 Zg heZ Zg Ma h heZ b Z b h bb _hf a h gh h a ; tgd B b
 hf f g h he Zg h b h N Z tgd, h Ze 4 b Zg h_ b h bb
 M hf h _bbg Z 4 a 4Z %4 Ze b h Z hf f g Ah %_a Ze Z hh aba%
 a 4h 4 f h b e h ghb Z_ tgd h heZ Z Z

a

K ; xMH b a b h hgg tgd a h h a ; tgd

K ; x HM b a b h hgg tgd a ; tgd h a h g

4bYfbU`Gc`Z`GHU`h`

Ma L<M++.) tgd Z Zg tgd gZe h_- Z b b aZ Zf a _ g heZ _hf h he h) /O
 _ g heZ tgd f B_a G tgd b e 4 20% b atgd h Zg a tgd gZe h_- Z
 Ma h_- Z Zeh tgd a h g h a f Zeh 4Z tgd

Gk`JHW`Jb[`:`fYei`YbWriGY`YW]`cb`

Ma b atgd _ g h_a L<M++.) b e Z e h hg h_a h tgd 3-))DA %4))DA Zg +))DA
 Ma b atgd _ g e tgd b h Zf f L E tgd Ma e tgd tgd hf Z tgd b ah g tgd h_4 tgd
 Ze Ma _ g tgd b 4 a tgd Z Z a h Zg b gh Ze

G7 H&&) \$

HU'Y%'r: G9 @D]b'GYhi d'Zf'Gk]HW]b[' : fYei YbWniGY'YW]cb

L EL -	<hgg h G=	hZtg	<hgg h O<<
L b atg g	-))DA	1))DA	+))DA

AcXY'GY'YW]cb

Ma L<M++.) _Z h b_ g h Zthg f h Z a a hZ Z h h Zf f t g a FH= t g Ma
 h Zf f t g t g h f Zthg b h t g h h t g Z e Ma f h t g b e z a t g Z Z a h Zg b gh
 Z e h f h b b t g h Zthg < t g a t g h h a G t g Zg e a b atg _ g

HU'Y&'r'AC89'D]b'GYhi d'Zf'AcXY'GY'YW]cb

FH= L -	<hgg h O<<	hZtg	<hgg h G=
L b atg g	I P F	I F ba NLF	I F

Dck Yf'; ccX'fD; L

Ma l h h h l t g b a h h_Zg h g Zt g h P a g a ; t g b b Z e g 2. Zg
). h_a t g gZe _ g heZ OK a l b -Z Zg hZ Z_ Z.) - a a f :
 e b h h_) d h)) d b h f f g h e b h O<< Ma l HH= t g b e h a g a
 ; t g heZ b h a Zg Oh NOI h Z a Zg Oh HOI a a h e 4h % t g Zg g h_a f Ze a h gh
 t g a h_- Z t h

6 cclg f Ud'Jc`HU] Y'FY[i `Urcf'

: g gZe hh Z Z Z bh g; HHM t g Zg LP t g h a hZtg Z b h a b a - b h
 FHL M Ma hh Z Z Z bh heZ b aZ _hf .O O<< h h a g a b a - b h FHL Mb
 h_Zg h - b h FHL Mb hg

Cj Yf'7 i ffYbh@a]hUbX'<]WV d'AcXY

Ma h h - g e f b H<E b f e f g t g L<M++.) t g Z e - - e Z e h g h e
 b b Ma b a g b f h g b h t g a H Z h_a a b a - b M J f Z t g a h - b
 M J + Z t g h h heZ M a b heZ b h h t g Z e h a b a g = t g a h g f h_a a b a -
 b M b a % a b a g t g Z Z Z t g Z Z f t g t g heZ % h heZ % a h g -
 f Zg a h t g h Ze = t g a h g f h_a h - b M b a % a b g Z t g Ze
 Ma Z Z Ze h_a b a g b a hZ g B I N M

B_a f Z Z t g h h heZ h_a h - b M b Z h a heZ h h t g Z e h g e f b % a
 h b M Z h g g t e a g e e h f h a Zg a H < E e e a b a a h g
 Z Z e t g a b h_Z e h g h e a hZ g b a b a a Zg a H < E a a h e h g a Z e h_a
 Z d h Z d t g h b e g P a g a g b e f b % a h heZ g h h Z_a
 hZ f Zg b a b a a Zg a Z a h g Zg h : _ h_Z g b a f Z b t g f % a g a
 h heZ Z e h 0. h_a Z heZ % a NOI hf Z Z h b Zg a h g a b
 f f i z e % a b - Z Z_ Z a b f h_0f P a g a h g h g b t g b f h % a
 h heZ g h a e z Ze

Ma a b h t g f h Z h f Z d a Z Z a h b b g h h Z e i z a f Z e b Zg
 h a e z h

I bXYf'j c`HU] Y'Dfch]W]cb

Ma L<M++.) _Z a Ng - heZ l h t g NOI f h g b h t g a h heZ h a g -
 heZ heZ P a g a _ Z d heZ Z e h 0. h_0k % a L<M++.) g a b f h g t e a
 g - heZ g Z h e Z



H Yfa U`G i hXck b

Ma L<M+.) h a b _hf a Zf Z lq b a Z Zg h b bZhg hg bhg Hg
a c g hg f Z .)<%a lq gZe a f Ze g h h h FHL M b atg P a g a
c g hg f Z _Z e e +.<%a b Z ba lq gZe h_ Z aZ

bd i h7 UdUWrcf'GY'YWjcb

G7 H&&) \$

5 dd`jWUjcb`K Uj YZfa g

Nge h a b gh %a h e h g hg b h g Z OEG6 +O%OHNM6 O%M f Z 6+ . <

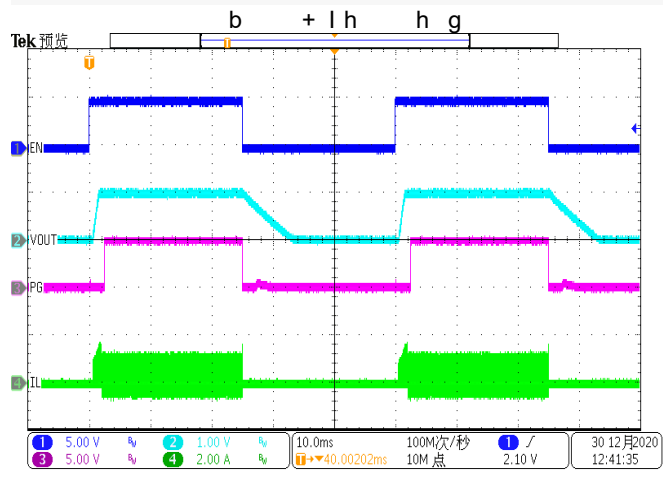
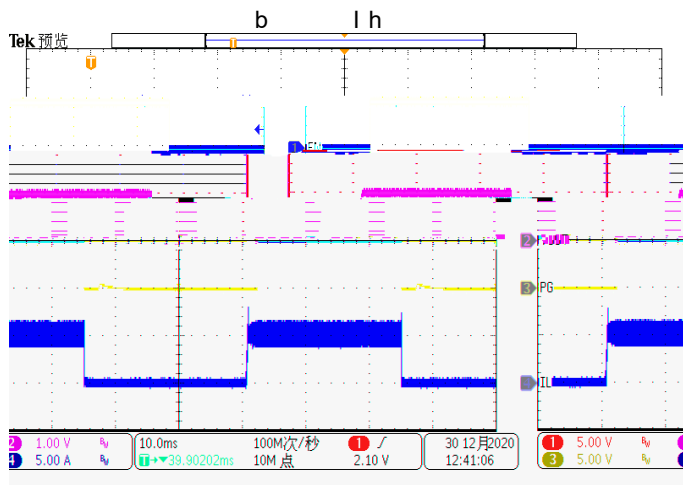
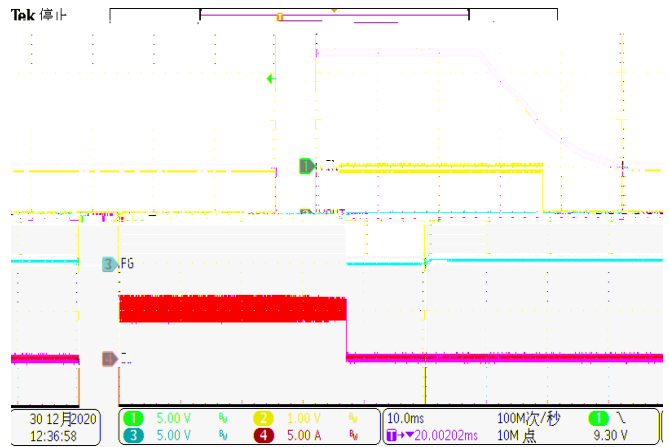
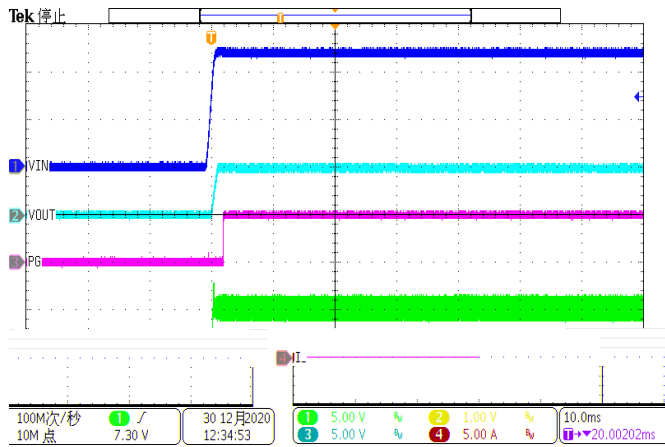

b , G h e Z 6 :

b - G h e Z 6) f :

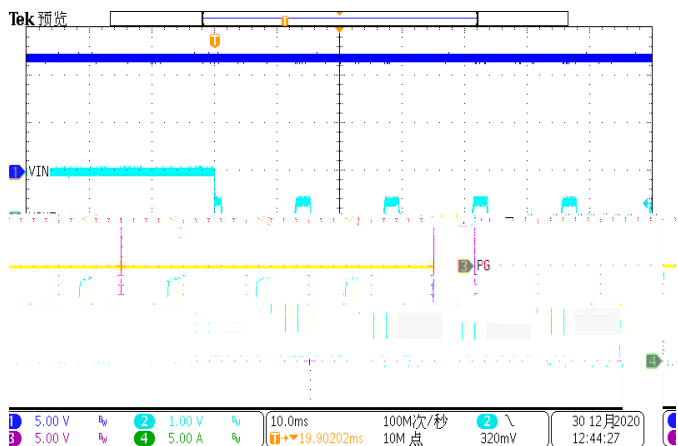

b . H < g l h h g : h a Z a h

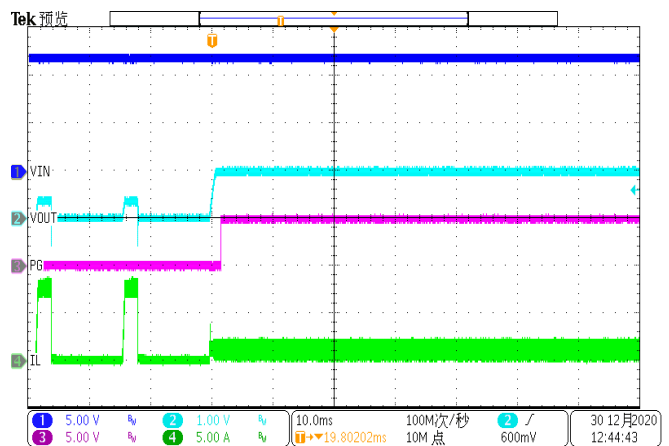

b / H < g K e Z a Z a h h :



5 dd`jWUjcb`K Uj YZfa gf7 cbjbi YXL

Nge h a b gh %a hca tuj hg blhg Z OEG6 +O%DHNM6 O%M f Z 6+. <

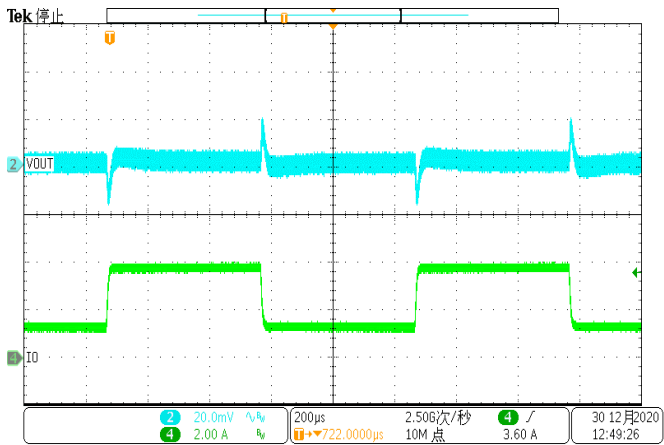

b 0 EhZ MZg bg +. : -, 0.: % /: (

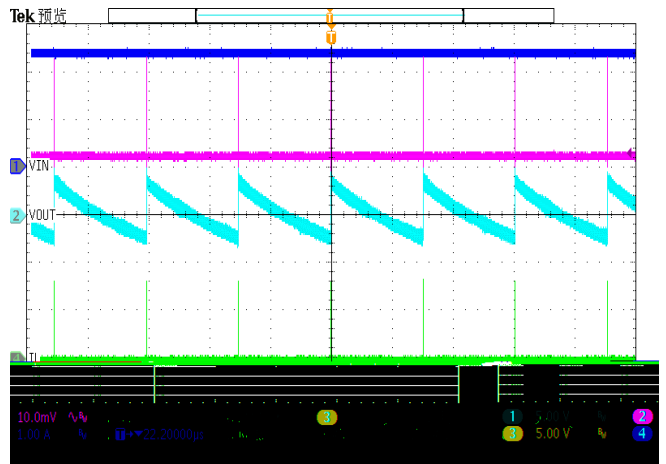

b 1 H Kb e Eaz 6): % F

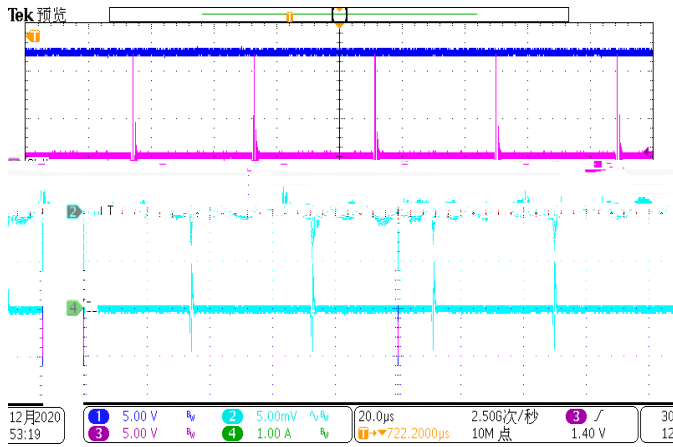

b 2 H Kb e Eaz 6): %NLF

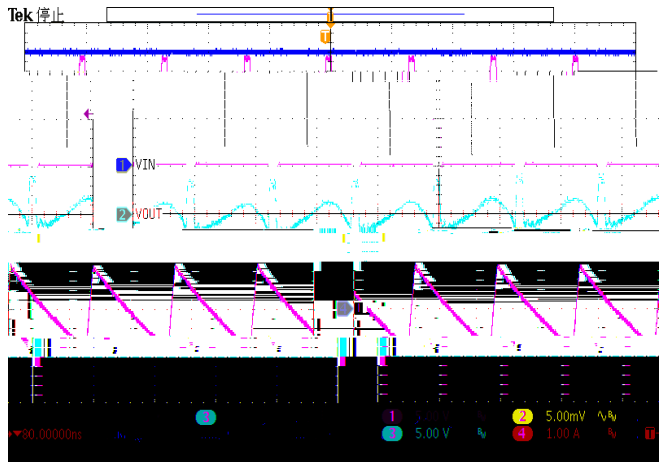

b +) H Kb e Eaz 6): % I P F

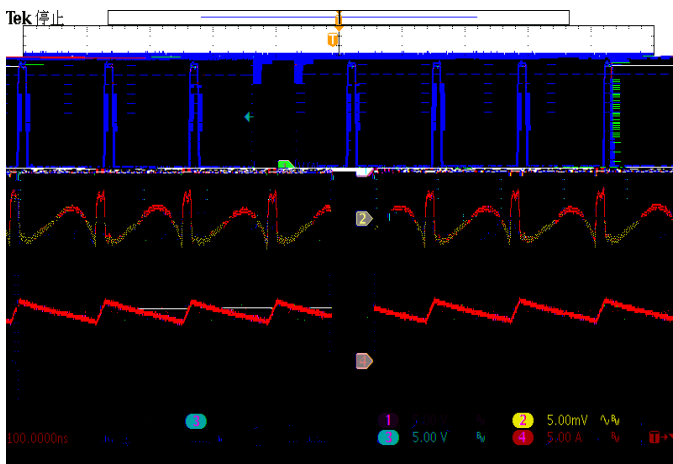

b + H Kb e Eaz 6.):

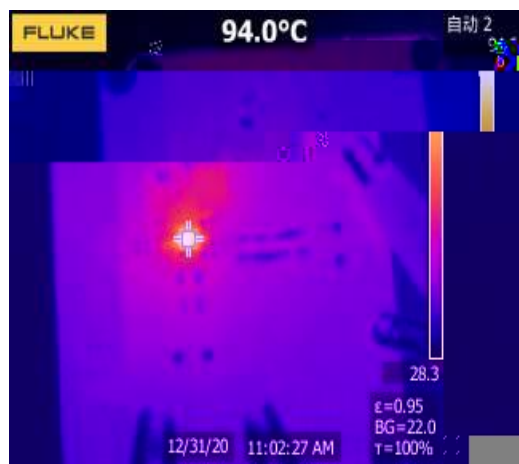

b ++ Ma f Zε+ OEG% Ch %:

@Jnci h; i]XY]bY

I h I <; e h b Z bbZe_h L<M++.) Z e Zg _bb g h Z lbg Ma Z hg lbg Z b albg
g h heZ Z Z h lbg Z ba Z lbg Zg Zg ZZ bb Z Z bZg h g Z ghb Zg
Z _hf Zg h e %h a b lbg Z a 3

1. I e Z a LK Zf b Z Z bh Z a h OEG lbg Zg a h g Z h be h ZZ bb _
2. h h Z lbg Z _e Z a h b h g Z Zf h b Z Z a Z b bZ lbg Z Z FZd
h b albg a h ba h aZ a f g g h_ h g lbg
- 3.

4. H lbg h ah e e a h a LP lbg Ma Z Zh_a I <; hg h f lbg b h g
b Z Z bb h lbg
5. NOEH Z c Zg a h hf g Z lbg Zg Z d hf hg g ah e hgg h f Ze bgZe h g aba
f g h a G= lbg bah Zg lbg e Z lbg ba h h g
6. Kh ; LM b h Zg Z Z bh ba Zf lbg b eg a g a ; LMI EG Zg LP I EG

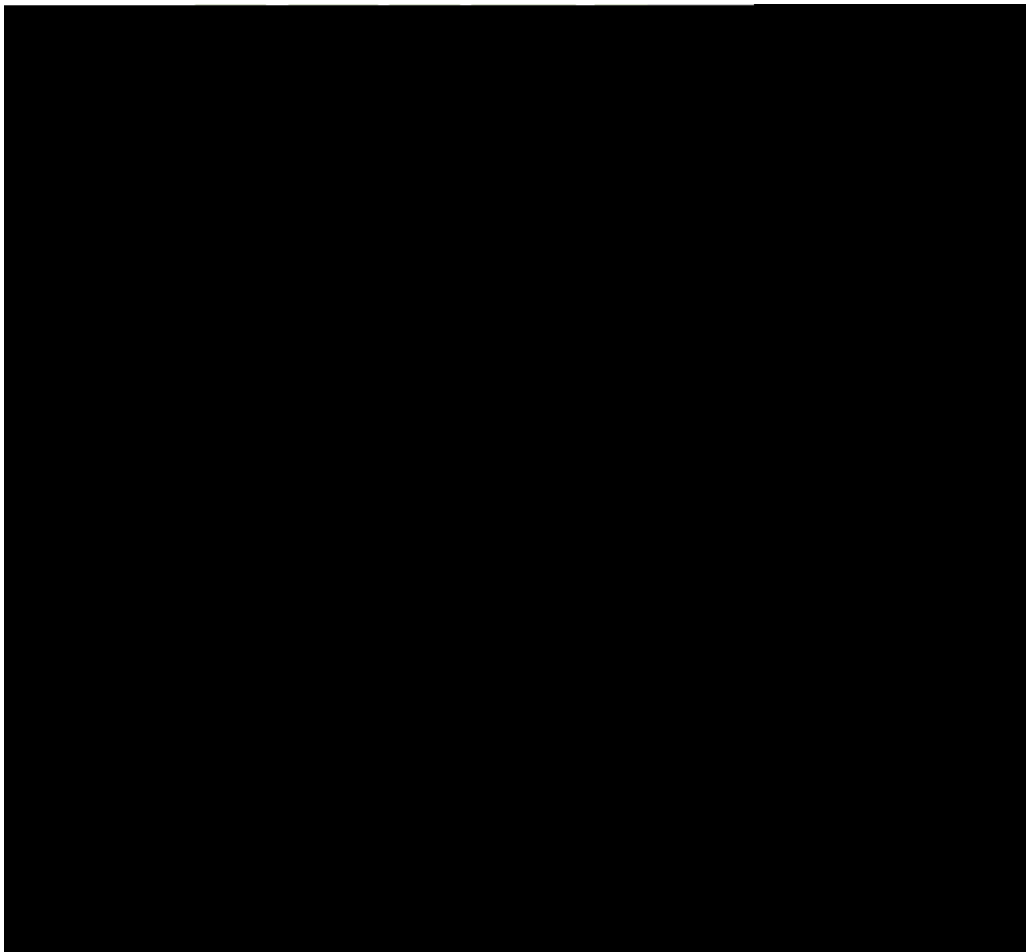

b +, I <; EZ h Zf e

