

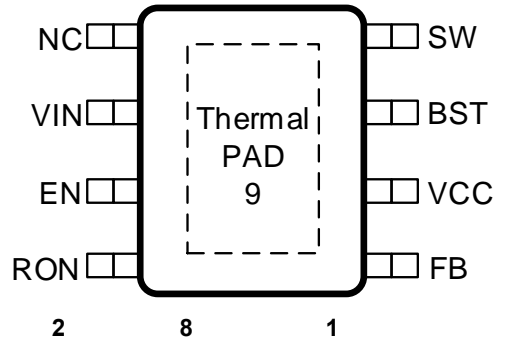

-

01 - . 81 01 5 1	- 7-353 1	- : 0- 0 - 7 =	- 7-31 - 753	5	- 7-31 01 5 5 :

01 5 5 :	5	-	: 5



- (1)
- (2)

: - 1	:	5 2 : 5 :
		a) b) c)

---

-

---

. 8	- - 1 1	1 : 0 5 5 :	5 -	: 5

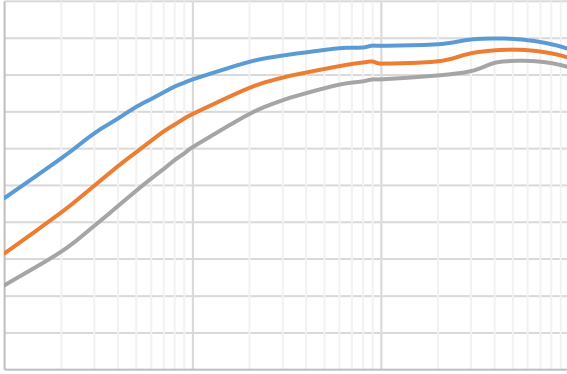

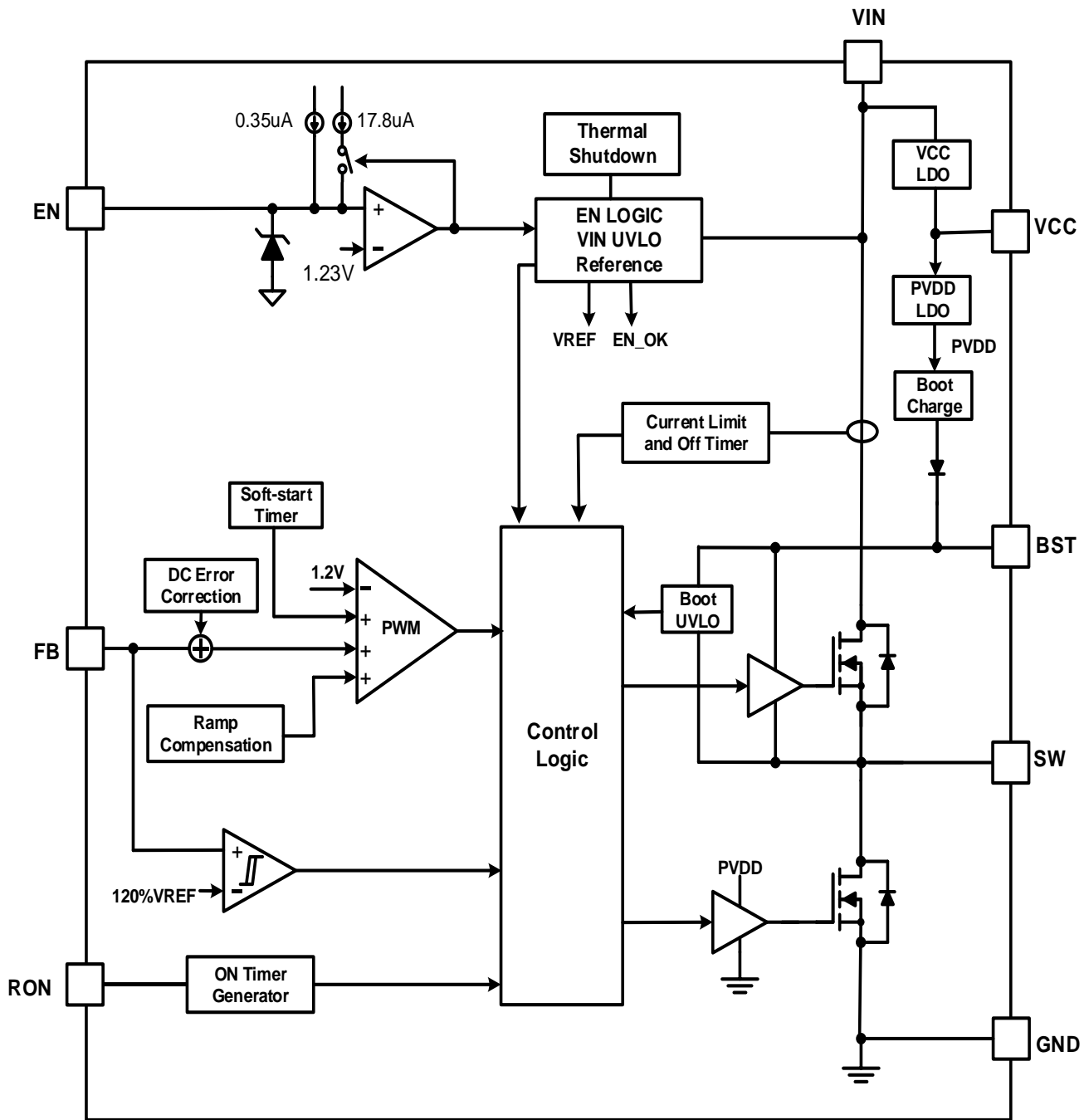

---

---

---

---

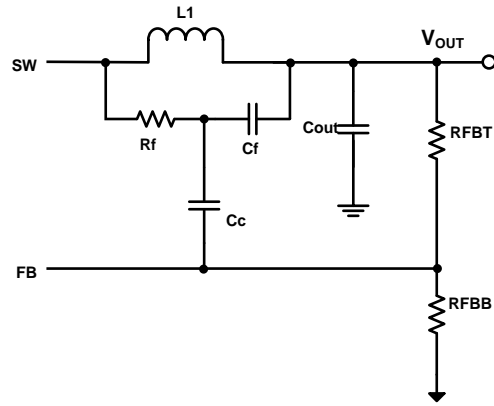

•  
•  
•

•  
•



---

1

8

---

-



Table 1. R<sub>1</sub>, R<sub>2</sub> Value for Common Output Voltage  
(Room Temperature)

---

---

- 
- 
- 
- 
- 
- 

---

---

---

- 
-

-

\_\_\_\_\_

\_\_\_\_\_

- 
- 
- 
- 
- 
- 

8

2 ) 74

---

8 . 2 ) 74

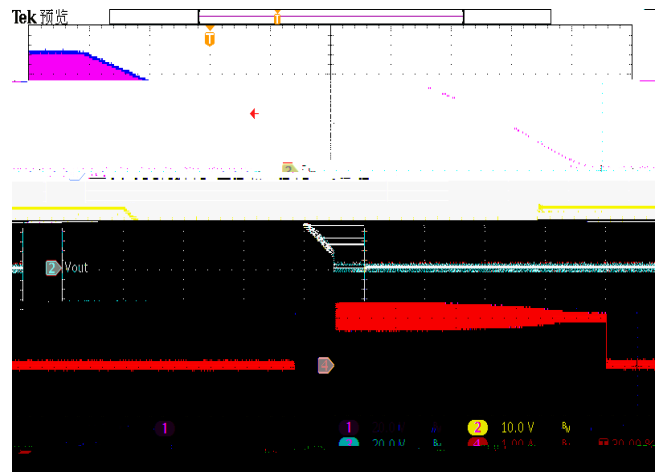
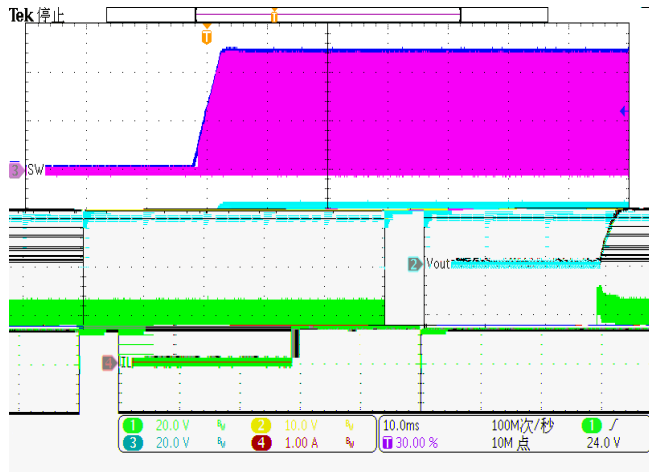

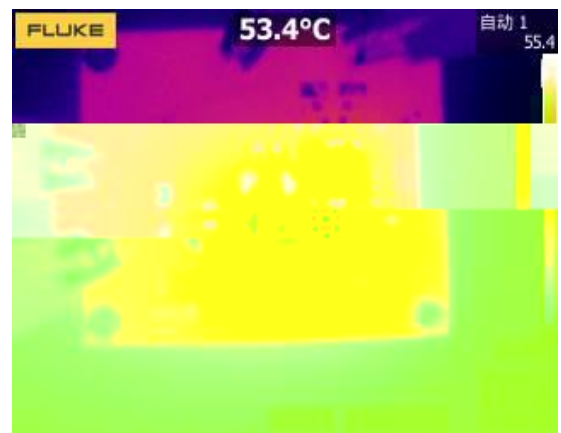
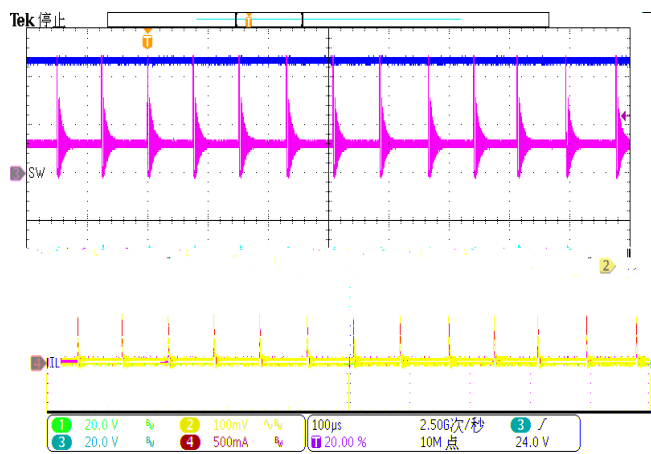
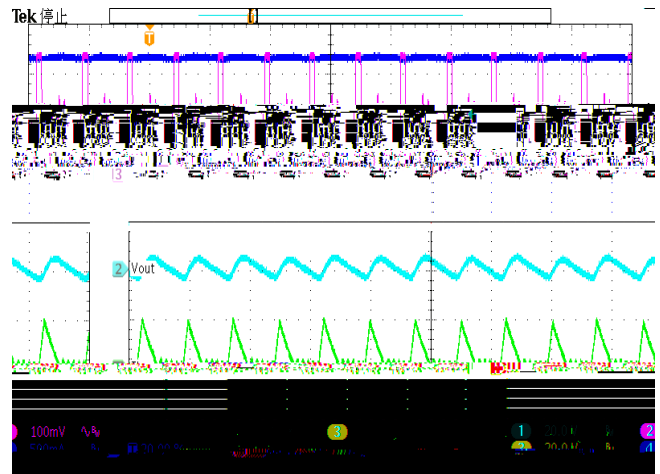
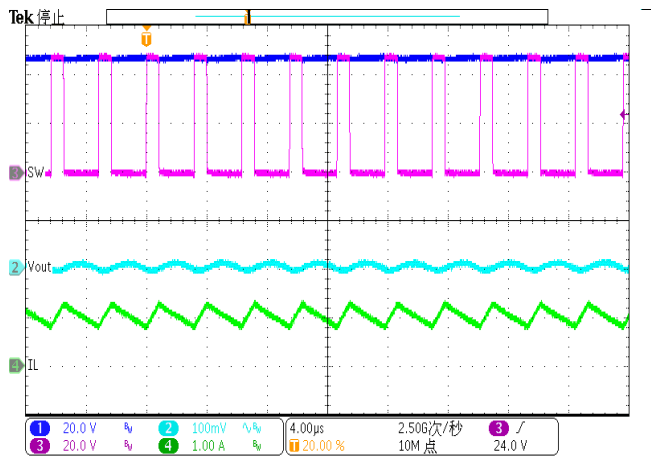
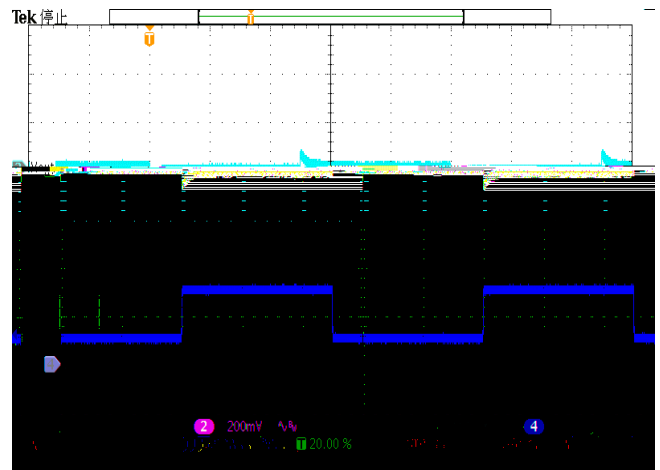
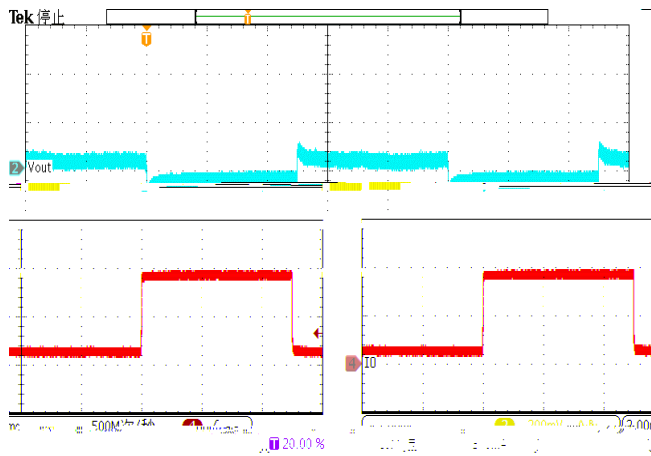

-

---

8 3

1.

2.

3.

4.



