

ç \$â3UH Ÿ "%45pH apNö "%45p©:-kÄHDFY r\$11 "y- CãNö G"mPH \$i8@"y7y€ffcC W! Ö4p0V L

(1)
(2)

--	--	--	--	--

--	--	--	--	--

--	--	--	--	--

--	--	--	--	--

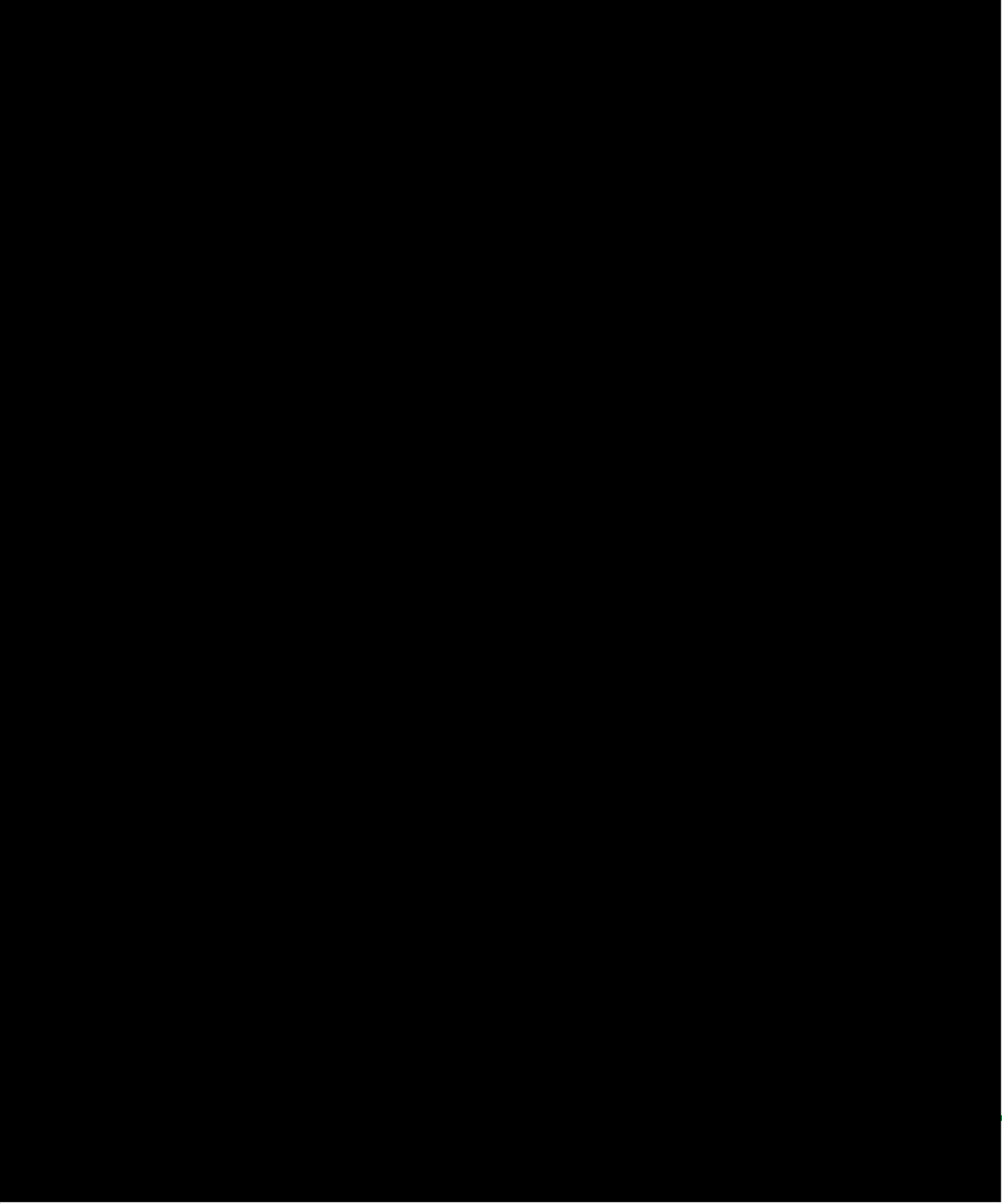

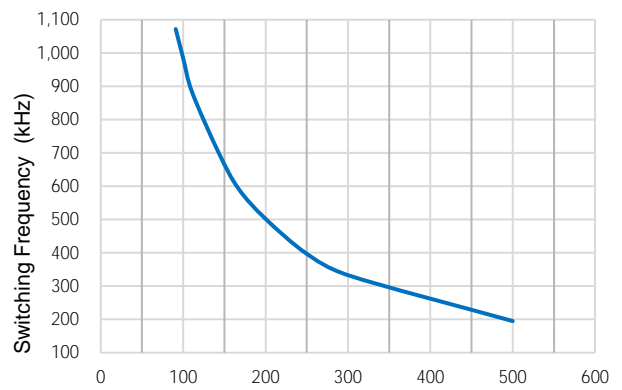
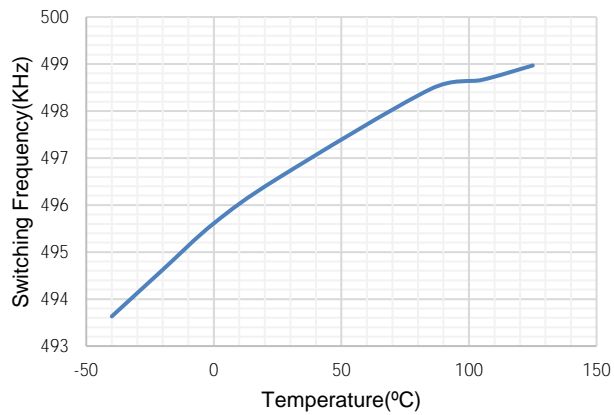
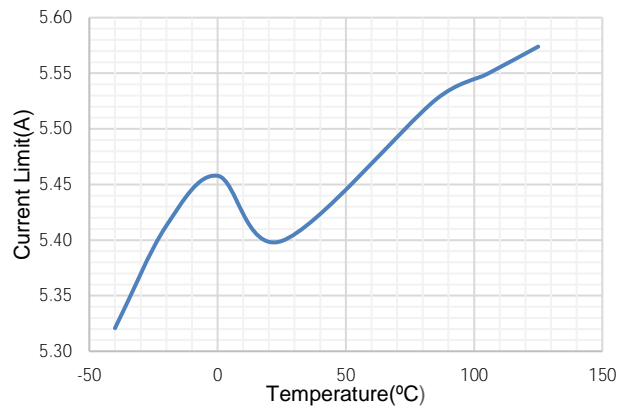
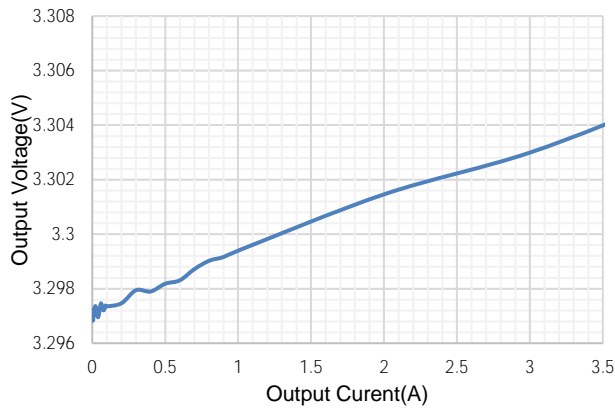
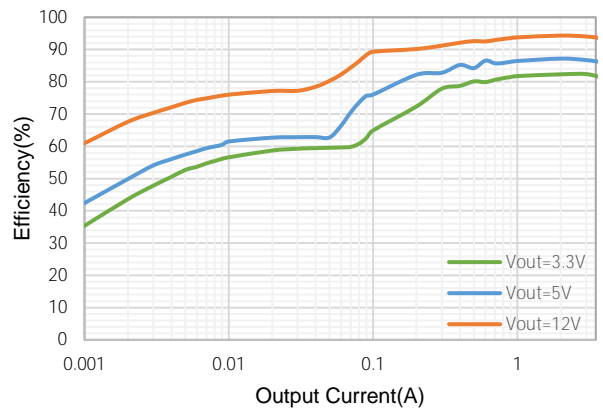
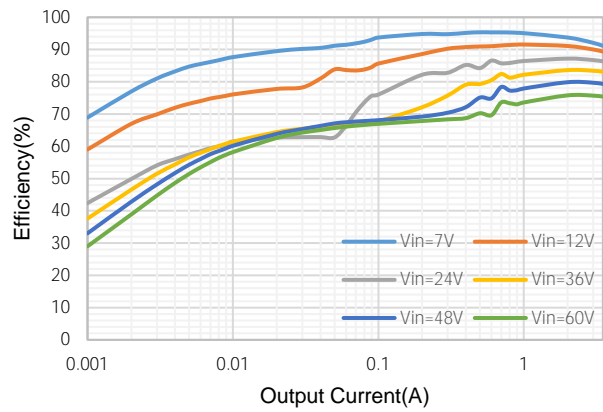

W H W K H

F X W R H V W H U U M I G K H O F W K H D L e G & F W R U

$$1 \quad \frac{0.875}{3.125}$$

$$2 \quad \frac{1 \quad 1.05}{1.05 \quad 1 \quad 4}$$

•
•

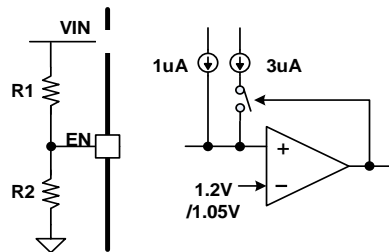

±

— 1 —

•
•

$$\frac{3}{0.8}$$

•
•

100000

5

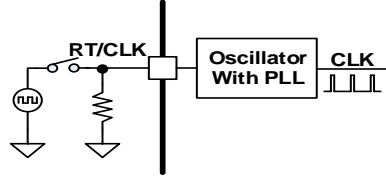

5 — 1 6

•



-
-
-
-
-

_____ 1 _____

-
-
-
-
-
-

$$\frac{\overline{2}}{2 \frac{1}{12} 2}$$

-
-
-
-



$$\frac{-}{-} = \frac{2}{2}$$

$$I_{CINRMS} = I_{OUT} \frac{V_{OUT}}{V_{IN}} = 1 \frac{V_{OUT}}{V_{IN}}$$

$$I_{CINRMS} = 0.5 I_{OUT}$$

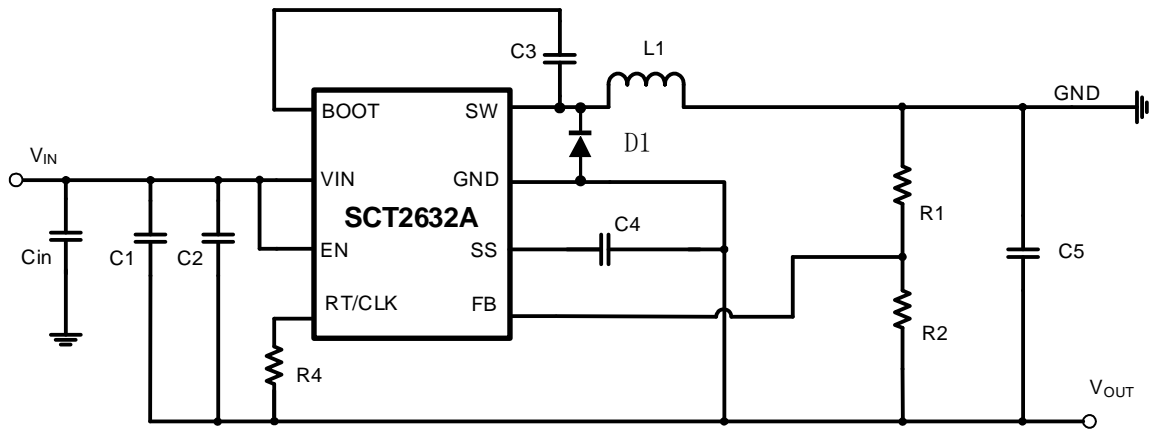

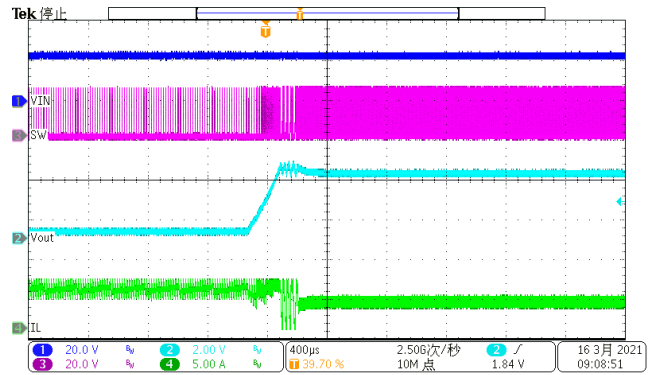
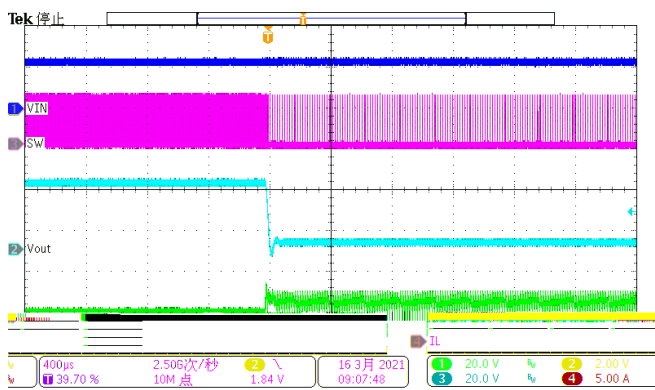
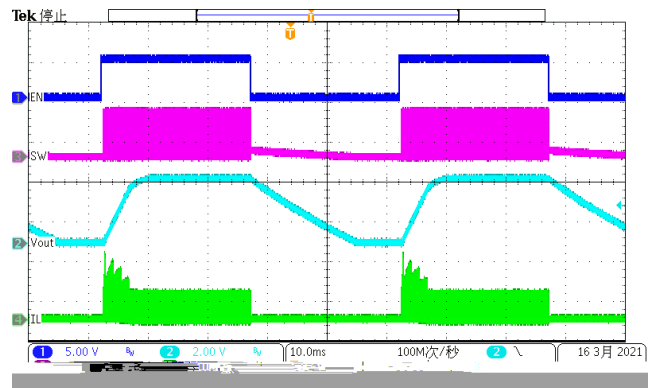
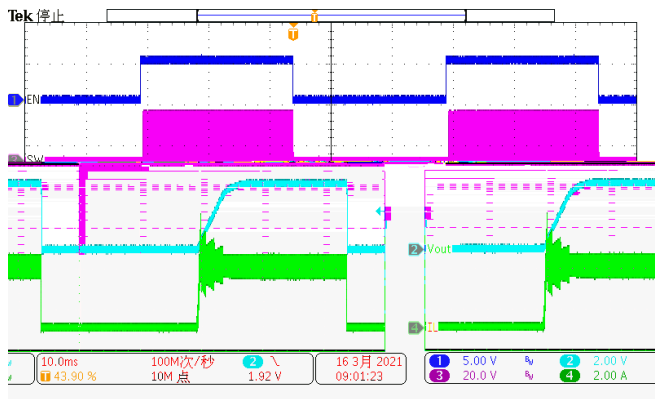
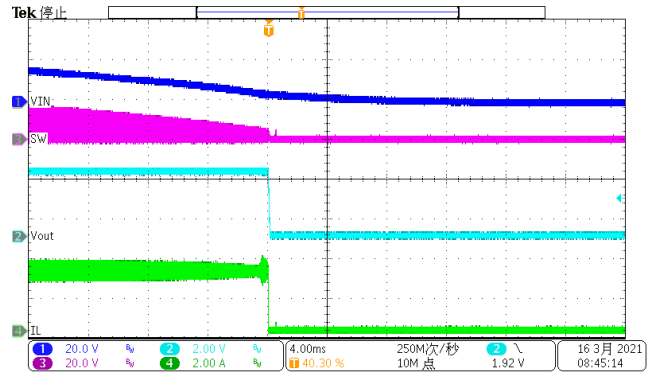
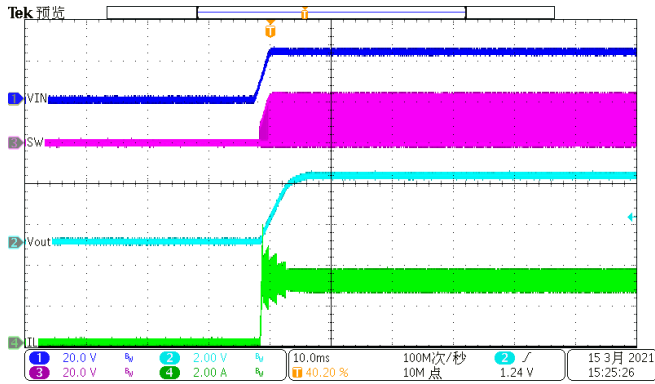

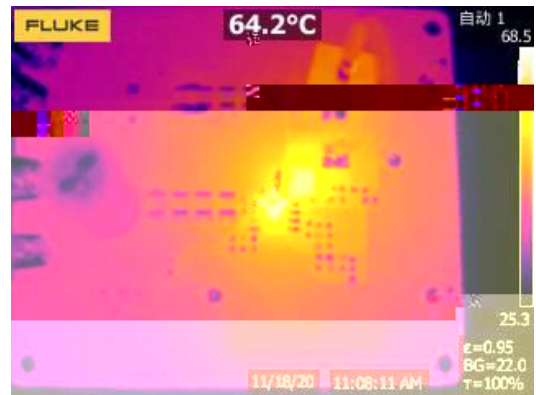
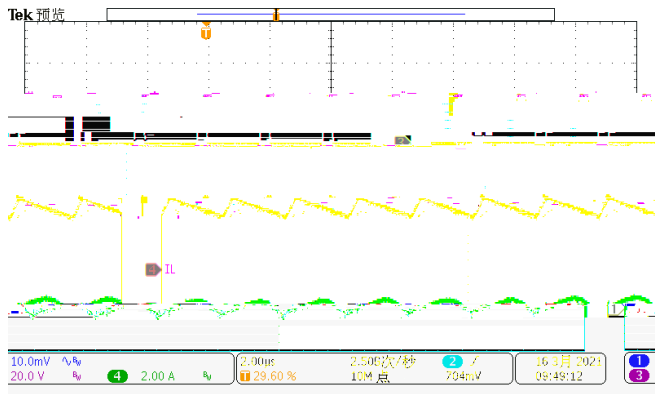
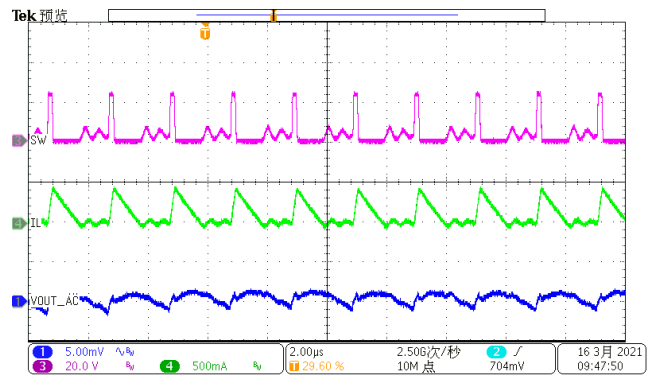
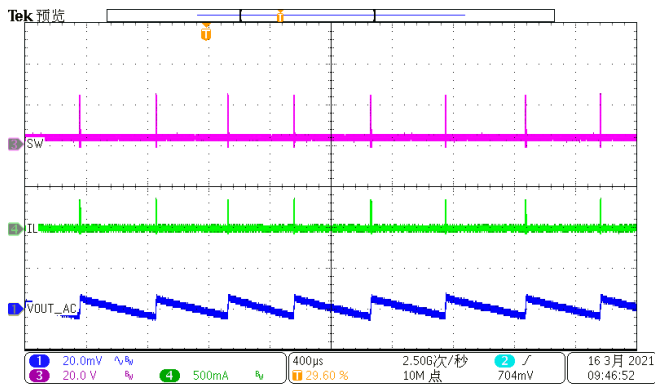
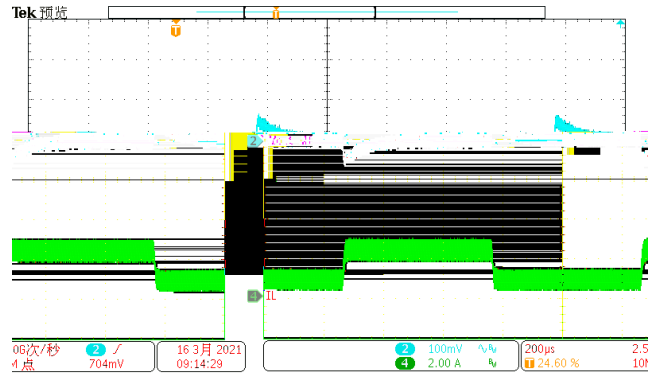
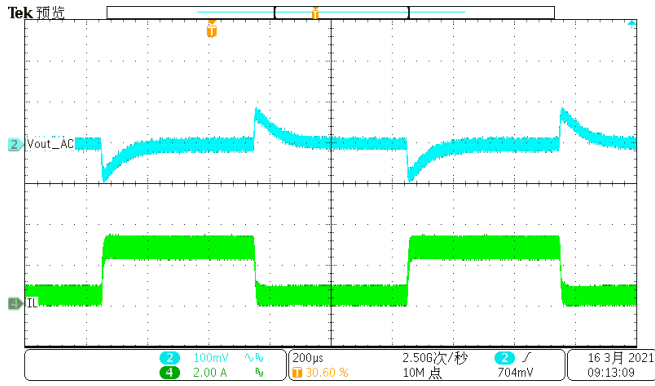

1.

